



# BALOO'S BUGLE



Volume 17, Number 2

"Make no small plans. They have no magic to stir men's blood and probably will not themselves be realized." D. Burnham

September 2010 Cub Scout Roundtable

October 2010 Cub Scout Pack Meeting

## RESPONSIBILITY

Tiger Cub, Wolf, Bear, and Webelos Meetings 3 and 4

### CORE VALUES

*Cub Scout Roundtable Leaders' Guide*

The core value highlighted this month is:

- ✓ **Responsibility:** Fulfilling our duty to God, country, other people, and ourselves. Cub Scouts will understand that everyone is responsible for fire prevention, and learn about the importance of keeping their promises.

*Catalina Council*

#### Responsibility:

Responsibility is fulfilling our duty to take care of ourselves and others.

Someone who is responsible will:

- ♫ Be dependable; do what you say you will do.
- ♫ Finish your homework.
- ♫ Take care of chores at home.
- ♫ Be helpful.
- ♫ Accept the consequences for your actions.
- ♫ Take care of your personal possessions.

### COMMISSIONER'S CORNER

Sorry, this issue kind of got out of control. I was trying to show a little bit for every requirement mentioned in weeks 3 and 4 of the new Den and Pack Meeting Resource guide. Many, many thanks to my "staff" - Jim, Alice and Joe who came through. And especially to our newest member, Wendy from Seattle!!! Next week, Donna and I take off for Germany to see the Passion Play in Oberammergau, "Lutherland" and many other places (e.g the castle that inspired Disney). Wendy has volunteered to produce Baloo's Bugle while I am in Germany. Thank you.

You can send Wendy a Thank You for the Table of Contents!! On my copy, it is clickable to get to the designated page!!! And be sure to read her Commissioners Thought.

You'll see Good Manners as the Special Opp as boys can certainly learn to be responsible for their behavior. And the Litterbug Audience Participation fits as we should be responsible and not litter.

I still don't see a place posted for Sam Houston's Akela Trails (Pow Wow) Training Day. Hopefully soon.

Responsibility is always discussed in reference to something – to be responsible to or for something. For example, the boys will learn to be more responsible with money and resources (conservation) later in the year. Because the topic of responsibility is so broad, there are many directions leaders can go with it.

This month the boys are learning about responsibility through the achievements and activity pins they are working on. The Tigers are learning to take more responsibility for their health by making better food choices. The Wolves are also learning to take more responsibility for their health, and are tracking their progress on their health charts. The Bears are learning to ride a bicycle responsibly, and to take care of their bicycles. The Webelos are gaining a deeper appreciation for nature, which will hopefully translate into greater environmental responsibility. And Arrow of Light Webelos are exercising (health & fitness responsibility) when they work on their Aquanaut.

Because responsibility is already built into this month's activities, leaders can easily work in a quick discussion about responsibility as it relates to what they are doing in their dens.

*Wendy*

### TABLE OF CONTENTS

*In many of the sections you will find subdivisions for the various topics covered in the den meetings*

CORE VALUES.....	1
COMMISSIONER'S CORNER.....	1
THOUGHTFUL ITEMS FOR SCOUTERS .....	2
Quotations.....	3
TRAINING TOPICS .....	4
Character Connections Part 2 .....	4
ROUNDTABLES .....	5
PACK ADMIN HELPS - .....	6
Youth Leadership In The Pack .....	6
Cub Scout Den Chief.....	7
SPECIAL OPPORTUNITIES .....	9
Good Manners .....	9
Boys' Life Reading Contest for 2010.....	10
Knots of the Month.....	10
GATHERING ACTIVITIES .....	11
Responsibility Activities.....	11
Food Activities .....	13
Fire Activities .....	14
Sports Activities .....	15

Bike Activities .....16

OPENING CEREMONIES.....17

AUDIENCE PARTICIPATIONS .....17

ADVANCEMENT CEREMONIES .....18

SONGS .....19

    Responsibility Songs.....19

    Food Songs.....19

    Fire Songs .....20

    Bike Song.....21

STUNTS AND APPLAUSES.....21

    APPLAUSES & CHEERS .....21

    RUN-ONS.....21

    JOKES & RIDDLES.....22

SKITS .....22

CLOSING CEREMONIES.....24

    Cubmaster’s Minutes .....24

CORE VALUE RELATED STUFF .....25

DEN MEETING REVUE .....27

    TIGERS.....28

    WOLVES .....28

    State Websites for Kids.....29

    BEARS.....30

PACK AND DEN ACTIVITIES .....31

    Food Activities .....33

    Fire Activities.....33

    Sports Activities.....34

    Flag Activities .....34

    First Aid Activities.....34

    Bike Activities .....35

MORE GAMES AND ACTIVITIES.....39

ADVANCEMENT IDEAS .....40

    Tiger Achievements .....40

    Tiger Electives .....40

    Wolf Achievements.....40

    Wolf Electives.....41

    Bear Achievements .....41

    Bear Electives .....41

    Webelos Activity Pins.....42

GAMES .....42

    Food Games .....44

    Fire Games .....45

    Sports Games .....46

    Bike Games .....49

    Law Enforcement Games.....50

CUB GRUB .....50

    "Food" Food.....51

    "Fire" Food.....53

    Sports Food .....53

    First Aid Food .....54

    Bike Food.....54

    Law Enforcement Food.....55

WEBELOS.....55

    Forester/Naturalist.....57

    Traveler/Athlete .....58

    Outdoorsman - .....59

    Sportsman - .....61

    More Webelos Stuff.....61

POW WOW EXTRAVAGANZAS .....65

WEB SITES .....65

ONE LAST THING .....65

**THOUGHTFUL ITEMS FOR SCOUTERS**

*Thanks to Scouter Jim from Bountiful, Utah, who prepares this section of Baloo for us each month. You can reach him at [bobwhitejonz@juno.com](mailto:bobwhitejonz@juno.com) or through the link to write Baloo on [www.usscouts.org](http://www.usscouts.org). CD*

**Roundtable Prayer**

*Scouter Jim*

“Great Creator, lead us and let us lead others and we shoulder our responsibilities to Thee, our country and our fellow beings. We accept this responsibility to ‘Do Our Best’. **Amen.**”

**Few things help an individual more than to place responsibility upon him, and to let him know that you trust him. Booker T. Washington**

**Teaching Responsibility**

Scouter Jim, Bountiful UT

There is a Scout Troop in our District, where the leaders sit calmly by at activities and watch youth leaders lead their Troop. As a Boy Scout Leader, I would tease the leaders of this Troop saying, all you do at camp is sit in a chair, drinking coffee with a fishing rod. The boys do all the work. This doesn’t just happen, it takes work to teach. It has been happening through many generations of Scouts. This troop is well organized and completely uniformed at all functions. Bountiful Elk’s Troop 220 is a model for others to achieve.

The following news story appear in Utah Newspapers this summer after a tragic automobile accident:

**Boy credited with saving children after southern Utah wreck**

*Deseret News, Wednesday, June 16, 2010*

*NEW HARMONY — A 12-year-old boy helped drag three younger children from a car accident that killed a New Harmony woman then walked a mile for help Monday.*

*The car's driver, Beth Donnelly, 24, died at the scene when the vehicle went off the edge of a steep embankment, said Washington County Sheriff's Chief Deputy Robert Torsigni.*

*"I remember we fishtailed and went off the edge," Cory Arnett told The Associated Press Tuesday.*

*Arnett helped pull Donnelly's 3-year-old daughter and two other children from the car, helped them up the embankment, and then walked a mile before flagging down a nurse.*

*When Cory checked Donnelly, he said she was bleeding and unresponsive.*

*"The medics said she died instantly — and I knew that. But it was my responsibility to get the kids out of there," Cory said.*

*The crash occurred on a steep dirt road outside New Harmony, Torsigni said.*

*The four children were treated for minor injuries at Valley View Medical Center in Cedar City and later released, Torsigni said.*

What would make a 12-year-old boy think it was his "responsibility to get the kids out" of the car. I don't know the principals in this story, but New Harmony is small town in a remote corner of Utah. Ten years ago the town of New Harmony only had 190 residents. This young man was most probably a Boy Scout, and may have even been the Den Chief in the Cub Scout Pack. Maybe he was not a Den Chief as that position is not as widely used as it should be.

My own son is the Den Chief in my Webelos Pack. He has been Den Chief for several years, even earning his Den Chief Service Award. Each Cub Scout Den needs a committed Den Chief. These young men lead and learn responsibility by serving others, while Cub Scouts learn both Scout skills and the value of service at the hands of an older mentor.

Not only does every Cub Scout Den deserve a Den Chief, they deserve to be able to serve as Denner and Assistant Denner and have the responsibility of leadership. This positions rotates often as required and allows all boys a change to serve, lead, and learn responsibility.

The best way to teach boys responsibility is to give them responsibility. It is often difficult for leaders to let go of some control and allow the boys to lead their own program. Young leaders don't always know what to do. Flag ceremonies can be taught to the Den, so that Denners can lead them at Den and Pack meetings by the Den Chief. Den Chiefs are the perfect way to teach many of these basic Scout skills. Let the older boys teach younger boys the things they have learned in Scouting and the younger scouts will "pay it forward" in time teaching others.

Let boy have some responsibility in leading their own program and they will take ownership and the whole program will benefit.

***See Den Chief Description under Training Topics***

### Quotations

*Quotations contain the wisdom of the ages, and are a great source of inspiration for Cubmaster's minutes, material for an advancement ceremony or an insightful addition to a Pack Meeting program cover*

If you want children to keep their feet on the ground, put some responsibility on their shoulders. [Abigail Van Buren](#)

Whether or not you have children yourself, you are a parent to the next generation. If we can only stop thinking of children as individual property and think of them as the next generation, then we can realize we all have a role to play.

[Charlotte Davis Kasl, Finding Joy, 1994](#)

"I must do something" always solves more problems than "Something must be done." [Author Unknown](#)

The willingness to accept responsibility for one's own life is the source from which self-respect springs. [Joan Didion](#)

Most of us can read the writing on the wall; we just assume it's addressed to someone else. [Ivern Ball](#)

We need to restore the full meaning of that old word, duty. It is the other side of rights. [Pearl Buck](#)

With every civil right there has to be a corresponding civil obligation. [Edison Haines](#)

I believe that every right implies a responsibility; every opportunity, an obligation; every possession, a duty. [John D. Rockefeller, Jr.](#)

We have the Bill of Rights. What we need is a Bill of Responsibilities. [Bill Maher](#)

Take your life in your own hands, and what happens? A terrible thing: no one to blame. [Erica Jong](#)

When you blame others, you give up your power to change. [Author Unknown](#)

The ultimate folly is to think that something crucial to your welfare is being taken care of for you. [Robert Brault](#)

Even when we know what is right, too often we fail to act. More often we grab greedily for the day, letting tomorrow bring what it will, putting off the unpleasant and unpopular. [Bernard M. Baruch](#)

I don't see the point of being a human being if you're not going to be responsible to your fellow human beings. Selfishness thefts away the human and reduces you to just a being. [Terri Guillemets](#)

The best years of your life are the ones in which you decide your problems are your own. You do not blame them on your mother, the ecology, or the president. You realize that you control your own destiny. [Albert Ellis](#)

Duty is what one expects from others. [Oscar Wilde](#)

For me the diamond dawns are set  
In rings of beauty,  
And all my ways are dewy wet  
With pleasant duty.

[John Townsend Trowbridge](#)

A new position of responsibility will usually show a man to be a far stronger creature than was supposed. [William James](#)

Mistakes fail in their mission of helping the person who blames them on the other fellow. [Henry S. Haskins](#)

You are not responsible for the programming you picked up in childhood. However, as an adult, you are one hundred percent responsible for fixing it. [Ken Keyes, Jr.](#)

God has entrusted me with myself. [Epictetus](#)

We have not passed that subtle line between childhood and adulthood until... we have stopped saying "It got lost," and say "I lost it." [Sidney J. Harris](#)

It is easy to ignore responsibility when one is only an intermediate link in a chain of action. [Stanley Milgram](#)

Action springs not from thought, but from a readiness for responsibility. [Dietrich Bonhoeffer](#)

The commands of democracy are as imperative as its privileges and opportunities are wide and generous. Its compulsion is upon us. [Woodrow Wilson](#)

No man was ever endowed with a right without being at the same time saddled with a responsibility. [Gerald W. Johnson](#)

We are made wise not by the recollection of our past, but by the responsibility for our future. [George Bernard Shaw](#)

*Alice, Golden Empire Council*

Some grow with responsibility, others just swell. *Anon*

Sometimes it's the smallest decisions that can change your life forever." *Keri Russell*

You cannot escape the responsibility of tomorrow by evading it today. *Abraham Lincoln*

If it's never our fault, we can't take responsibility for it. If we can't take responsibility for it, we'll always be its victim.

*Richard Bach*

Bobby of the Brady Bunch at first loved the recognition of being the Safety Monitor for his class – but responsibility took away the fun!

## TRAINING TOPICS

Wendy from Chief Seattle Council found this wonderful website for building character -

<http://www.goodcharacter.com/>

Check it out. Lots of great material you can use.

### Its Guiding Principles are:

- ★ Your character is defined by what you do, not what you say or believe.
- ★ Every choice you make helps define the kind of person you are choosing to be.
- ★ Good character requires doing the right thing, even when it is costly or risky.
- ★ You don't have to take the worst behavior of others as a standard for yourself. You can choose to be better than that.
- ★ What you do matters, and one person can make a big difference.
- ★ The payoff for having good character is that it makes you a better person and it makes the world a better place.

**Website correction** - Last month I listed a summary of Character Connection references in Cub Scout material with the wrong link. The correct link is -

<http://www.cubroundtable.com/assets/pdf-documents/2002-2010%20Character-Connections-Packet.pdf>

## Character Connections Part 2

Carol E. Little

In the earlier column, we learned about the history behind **Character Connections (CC)**. We discussed the three different components – **Know** –become familiar with all 12 core character connections (head), be able to **Commit** (heart) to doing the CC values and put them into practice in their daily life (hand) on their own initiative.

For part of this column, I'd like to use a piece that I ran into from the special needs section from **Heart of America Council Pow Wow** book for 2005. I think that by using some of these activities we can use the Character

Connections values and give our scouts a way to connect to others who have special needs.

**Wear glasses that have been smeared with Vaseline to simulate impaired vision.** *What did you experience while wearing the glasses? What did you learn from about yourself? What was the purpose of trying the glasses?*

**Use a balance board with a circular board with an "x" below also circular, to simulate inner ear problems.** (see **teeterboard jousting in the How-To Book**) *What did you like about this exercise? How did you feel while standing on the board? What did you learn?*

**Set up a blind man's maze, using wooden timbers to layout the maze. Each Cub was blindfolded, given a stick to tap out his way, and turned loose in the maze. Wow! Was that a site to see!** *What would you do differently in this exercise? How did you feel when you started to get around? What did you learn?*

**Type out the Cub Scout Promise and the Law of the Pack on computer then use a font to change the words to symbols such as MT Extra, Mobile, Cairo, Webdings, Symbols, Zapf Dingbats. Have the boys figure out what they say.** *What was the best part of this activity? Why do you think this activity was a good idea to do?*

**This exercise simulates vision challenges. Fill a bowl with pony beads and add 1 or 2 slightly larger different colored beads. The object is to pick out the larger bead of a specific color. The boys will always pick up one of the larger beads, but not necessarily the right color.** *What was the purpose of this game? What did you learn about yourself?*

These are activities that are designed to give the boys the chance to experience the frustrations faced daily by people with disabilities. Unless a person has experienced a disability we really have no idea what others face day to day. Treat the disabled Scout with all the respect and consideration that you do with other Scouts. If the game being played requires a blindfold, the blind or visually impaired Scout should be given one as well. If the Scout is in a wheelchair, don't stand over him to talk to him bend down to communicate face to face. If a hearing impaired scout has a signer, respond to the Scout not the signer. Our scouts look to us to set the example.

Games from **Woods Wisdom** 1996

**Foggy Harbor** Object: The group must maneuver an "oil tanker" (one member of the group) without bumping into the other "ships" (the remaining members). The oil tanker must be blindfolded. He is not to touch any of the other ships. These ships are distributed throughout the area. They remain stationary. As the oil tanker approaches on hands and knees, the nearest ship starts giving a warning signal, like a foghorn. The oil tanker then approaches slowly and attempts to maneuver across the harbor without colliding. *What was the purpose of this game? What would you do differently? What was the best part of this game?*

**Everybody Up** This exercise is a useful way to introduce the idea of group cooperation. Ask 2 scouts of about the same size to sit on the ground or floor facing each other with soles of their feet touching, knees bent, and hands tightly

grasped. From this position they try to pull themselves into a standing position. If they succeed, ask another scout to join them and try standing with 3 scouts, then 4, etc. As the group grows, each player must grasp the hand of another person and must maintain foot contact with the group. An expanding group will find that thinking is required to come up with a solution that allows large numbers to get Everyone Up. What got you all going in the right direction? What would you try differently to get everyone up?

**Bell Tag** Equipment: Neckerchiefs or blindfolds and a hand bell. Method: Blindfold all scouts except the one who has the bell. Have blindfolded scouts mill around the room. The scout with the bell moves among the others, ringing his bell constantly. The blindfolded scouts try to tag the bell ringer. The scout who succeeds changes places with the bell ringer. What did you feel while playing this game? What did you learn from this game? What was the best part of the game?

*I hope that you all had fun learning how to use Character Connections in your den and pack activities.*

Examples found in the 2005 **Character Connections Packet** are collected from 2002 to present so that future Leaders will have the resources we had from the beginning.

**To learn more check out Character Connections The Purposes of Cub Scouting and Character Connections**

How Character Connections are used as part of the requirements.

**To learn more check out Character Connections The Purposes of Cub Scouting and Character Connections**

How Character Connections are used as part of the requirements.

[Character Connections Chart #13-323A](#) Chart explaining Character Connections

[2010 Character Connections Packet](#) Examples of the different areas covered by Character Connections from past Program Helps (from 2002 to 2010), Roundtable Resource sheets, and the 2003 Cub Scout Books.

[Character Connections Data](#) Some history behind the program.

[Character Connections](#) Overview of all ranks on a chart.

[C Connections Outdoor Grid](#) Ideas for outdoor activities.

\*\*\*\*\*

**What are YOU going to do now?**

*The best gift for a Cub Scout.....  
.....get his parents involved!*

✓ **Be sure to visit Bill Smith's website**

<http://rt492.org/>

to finds more ideas on everything Cub Scouting.

The Den Chief column was taken from one of Bill's from 2007. He has officially retired from Baloo's staff - and is missed. He wrote me - "Come October, I will have completed my 48th year as an adult Scouter. It's probably time I started taking it easy. **But I am interested in learning about the experiences that CS leaders have with the CS-2010. Reach Bill Smith at wt492(at)wtsmith.com.**

*Send him a Thank you for all he has done - his website and contributions to Baloo. CD*

\*\*\*\*\*

**ROUNDTABLES**

[Beverly, Capital Area Council](#)

*Beverly is one of the nice ladies behind the counter at her council service center (No one says Headquarters anymore) that greet people as they arrive. (That is her description not mine) She was on several CS RT Planning Guide Task forces with me. Let's welcome her with a big "Class A" applause. CD*

Have you ever wondered how many people attended Roundtable once and never came back? And why? These are questions that make the Roundtable Commissioner and his/her staff pull their hair out! I am sure all of us have some sort of attendance gimmick to get folks in the door. Let's face it - adults will do almost anything for a bead or a feather. And if the beads, etc are fancy enough, that may keep folks coming back for a while. But all the gimmicks in the world won't keep folks coming if the program is not good.

*So attendance is a two pronged attack - and we become the "Get 'Em, Keep 'Em Gang" (Thank you Joe Hipius!)*

**"Get 'Em" (in the door):**

- 1. Is there some sort of recognition of attendance every month?
- 2. Do you recognize Packs as well as individuals? We have a traveling pack attendance trophy that the pack with the most folks present gets to take home and decorate (and display at their pack meeting and bring back to Roundtable the next month).
- 3. Do you make a big deal about 1<sup>st</sup> timers? We also recognize 4-timers with a "Fantastic Four" neckerchief slide (attend 4 roundtables and qualify for your leader knot).
- 4. Do you change up the awards from time to time?

**"Keep 'Em" (coming back for more)**

- 1. Are you using the Roundtable Planning Guide? A team of hard-working volunteers spent lots of hours on this and the agendas do work.
- 2. Are you doing position specific break-out sessions?
- 3. Do you provide a handout - at least the Resource page from the Roundtable Planning Guide?
- 4. Do the participants have the opportunity to ask questions? (How is the Parking Lot poster working? - I have never gotten people to use these at training and last month's Roundtable was no different)
- 5. Do you provide the latest district and council news? And is your DE available before, during and after the meeting?
- 6. Do you watch your time?
- 7. Have you asked your participants to complete an evaluation form lately?
- 8. Is everyone, including the staff, having fun?

I know there is no one way that would generate attendance for everyone of us. We have to go with what works for our particular district roundtable situation. Good luck and may your roundtables be filled with many happy, energetic leaders! Drop me a note about what you have done that boosted attendance for you!! [Bev](#)

Here is part of a grid Wendy developed so you can see at a glance what is going on in the dens. (Keep in mind not everyone in a pack will necessarily be on meeting #X the same week or month.)

MONTH/ CORE VALUE	SEPTEMBER: COOPERATION		OCTOBER: RESPONSIBILITY		NOVEMBER: CITIZENSHIP	
	1	2	3	4	5	6
<u>TIGERS</u>	Bobcat	Ach. #1 Making My Family Special	Ach. #3 Keeping Myself Healthy & Safe	Ach. #3G Sports field trip	Ach. #5 Let's Go Outdoors	Ach. #2 Where I Live & Ach. #4 How I Tell It
<u>WOLVES</u>	Bobcat & Ach. #2 Your Flag	Ach. #2 Flag & Ach. #1 Feats of Skill	Ach. #2 Flag & E #20 Sports	Ach. #3 Keep Your Body Healthy E20g Bowling	Ach. #4 Home & Community Ach. #9 Be Safe	Ach. #4 Home & Community E#9bc gift E#11a Singing
<u>BEARS</u>	Bobcat Ach. #6 The Past Ach. #16 Building Muscles	Ach. #3 America Ach. #9e Community History	Ach. #14 Ride Right	Ach. #7 Law Enforcement	Ach. #1 Worship Ach. #7 Law Enforcement Ach. #20 Tools	Ach. #20 Tools Ach. #15 Games
<u>WEBELOS</u>	Fitness & Athlete	Forester & Naturalist	Forester & Naturalist	Traveler & Athlete	Citizen	Citizen
<u>ARROW OF LIGHT</u>	Family Member	Aquaman	Outdoorsman	Sportsman	Scientist	Scientist & Arrow of Light
<u>PACK NIGHT THEME VALUE</u>	Cooperative Games (Cooperation)		Fire Safety (Responsibility)		Citizenship & The Flag (Citizenship)	

## PACK ADMIN HELPS - Youth Leadership In The Pack

*Developing Leadership in Boys is what it is all about!!*

### The Denner and Assistant Denner

*Scouter Jim, Bountiful, Utah*

The **Denner** and Assistant Denner are the most important youth leadership positions in Cub Scouts. A Denner is a **Cub Scout** or **Webelos Scout** who is elected to be the temporary youth leader of his den. All Tiger Cub, Wolf, Bear, as well as Webelos Dens should elect a **Denner**. A den may elect a new **Denner** every few weeks, monthly, or other term. The Denner wears the gold double-strand [Denner shoulder cord](#) [No. 00368](#) over his left shoulder.



#### Importance

The Denner position provides many important benefits to the boy and to the den:

- ★ Each boy serving as a Denner earns parts of various rank requirements. *Dens should rotate the position so that all members serve as a Denner at least once.*
- ★ Denners learn about leadership and responsibility first-hand.
- ★ The Denner program helps give every boy a fair chance to lead.
- ★ Each family shares equally in helping the den leader.
- ★ The Denner position is preparing boys to be Patrol Leaders in Boy Scouts.
- ★ Scouts and parents who are allowed to help are more like to stay in Scouts.
- ★ Denners are recognized by being allowed to wear the Denner's [gold cords](#).

#### Rotation

Certain ranks require that every boy serve as Denner. Also, the Denner leads the flag and opening ceremony as required for various ranks. However a popular boy who is re-elected may deny others the opportunity to learn and advance. For this reason, the Den Leader may decide that boys who have already served as Denner may not be elected again until every other boy has had a turn. Alternately, a single Denner election may be held at the beginning of the year to determine the Denner schedule for the year, with new den leaders rotating monthly or of every few weeks.

In the lower cub ranks, Denner elections may not be the best approach, as you commonly end up with each boy voting for themselves, or boys getting very upset when they do not win

*From Bob Scott at National in answer to my question on the role of Roundtables with the new delivery system - Dave, you have it right.*  
**No changes to roundtable's role, how it's executed, etc.**  
 Bob Scott , Innovation Coordinator - CS 2010

the election. Some possible approaches are to appoint them in alphabetical order, or by drawing names from a hat.

By Webelos age, the boys should be able to handle elections, and this will be a good lead-in for [Patrol Leader](#) elections within Boy Scouts.

### Responsibilities

The Denner (typically along with his parent or adult partner) have many important duties as assigned by the Tiger Cub Den Leader, Cub Scout Den Leader or Webelos Den Leader that may include:

- ★ Help with den meeting setup.
- ★ Lead the opening ceremony (flag, oath, law).
- ★ Take the Den Attendance and dues meetings.
- ★ Help with the meeting activities.
- ★ Provide simple refreshments such as cookies and cups of juice.
- ★ Lead the closing ceremony.
- ★ Help with den meeting cleanup.
- ★ Help with other responsibilities as assigned by the Den Leader.

### Assistant Denner

The Assistant Denner assists the Denner at den meetings and fills in for the Denner when the Denner is not available. The Den Leader may establish a practice of the Assistant Denner becoming the Denner in the next term. This way the Assistant Denner can watch and learn from the Denner so that he will be ready for the next term. Using this approach, the Assistant Denner is elected each month to become the Denner the next month.

The Assistant Denner wears the gold single-strand [Assistant Denner shoulder cord No. 00385](#) over his left shoulder.



### Cub Scout Den Chief

*Scouter Jim, Bountiful, Utah*



### What is a Den Chief?

The Den Chief is an older Boy Scout, Varsity Scout or Venturer who works with a Cub Scout or Webelos den. He is selected by the Scoutmaster and the troop Senior Patrol Leader in cooperation with the Cubmaster. He may be of any age or rank, but he can be the greatest help if he is a former

Cub Scout and if he is mature enough to assume this important **responsibility**. As a selected leader of younger boys, he has the opportunity to help them complete their Cub Scout or Webelos Scout advancement requirements and live up to Cub Scouting's ideals in their everyday lives.

The Den Chief is a member of a leadership team which also includes the den leader, assistant den leader, and the denner. **The den chief is already what every Cub Scout and Webelos Scout would like to be - a Boy Scout.** As far as the younger boys are concerned, he is the person they would most like to follow, and that makes him a natural leader for them. By directing this natural leader wisely, we can influence the den of boys under his leadership

### Responsibilities:

The Cub Scout den chief's responsibilities are to

- Know the purposes of Cub Scouting.
- Help Cub Scouts achieve the purposes of Cub Scouting.
- Serve as the activities assistant at den meetings.
- Set a good example through attitude and uniforming.
- Be a friend to the boys in the den.
- Help lead weekly den meetings.
- Help the den in its part of the monthly pack meeting.
- Know the importance of the monthly theme and pack meeting plans.
- Meet regularly with the den leader to review den and pack meeting plans. Meet as needed with adult members of the den, pack, and troop.
- Receive training from the den leader (and Cubmaster or assistant Cubmaster) and attend Den Chief Training.
- Encourage Cub Scouts to become Webelos Scouts when they are eligible.
- Help the Denner and assistant Denner to be leaders.

### Den Chief Service Award

[www.usscouts.org](http://www.usscouts.org)

**Before you begin work on this service award, discuss with your Den Leader and either your Scoutmaster, Varsity Coach, Venturing Adviser, or Cubmaster the role and importance of the Den Chief.**

1. Serve the pack faithfully for 1 full year.
2. Attend a den chief training (if available within year of service) OR be trained by the assistant Cubmaster and den leader.
3. Know the purposes of Cub Scouting.
4. Help Cub Scouts achieve the purposes of Cub Scouting.
5. Be the activities assistant in den meetings.  
**(lead five songs, five stunts or skits, five games, five sports activities)**
6. Set a good example by attitude and uniforming.  
**(for a minimum of six months)**
7. Be a friend to the boys in the den.
8. Take part in weekly meetings.  
**(for a minimum of six months)**

9. Assist the den at the monthly pack program  
(at least three times)
10. Meet as needed with the adult members of the den, pack or troop.
11. Complete FOUR of these projects:
  - A. Serve as a staff member of a Cub Scout special event, such as a Scouting show, bicycle rodeo, etc.
  - B. Serve as a staff member of a Cub Scout Day camp or resident camp.
  - C. Advance one rank.
  - D. Assist in recruiting three new Cub Scouts.
  - E. Assist three Cub Scouts to become Webelos Scouts.
  - F. Assist three Webelos Scouts to join a troop.
  - G. Help to plan and carry out a joint pack-troop activity.
  - H. Recommend to your Scoutmaster, Varsity Scout Coach, or Venturing Adviser another Boy Scout, Varsity Scout, or Venturer to be a den chief.

The following is from Bill Smith's Training Tip on "The Role of a Den Chief" in the January 2008 issue of Baloo's Bugle. It may be found on his web site at [Den Chief Training Tip](#). CD

### Den Chiefs are gods.

Den Chiefs don't make your job much easier, but they do make the Cub Scout experience better. They require coaching and direction to be successful but when they succeed they bring a unique spark to a Cub Scout's life that no one else can. Most children today live in an age-stratified culture where there is little interaction between older and younger kids. Just having an older Boy Scout take an interest in a seven or eight year old is a big deal. When a Webelos Scout visits a troop and one of the older Scouts recognizes him and even knows his name, it's an even bigger deal. These relationships can play an important part in a boy's growth and the effects may be long lasting.

But don't expect a young teen-age lad to be a natural leader. He needs help: coaching, support and acceptance. He must feel that he is a true member of the leadership team. Include him in the planning of your program. Give him explicit responsibilities. As he gains confidence, he will surprise you with his abilities.

### Who should be a Den Chief?

Any Boy Scout or Venturing Crew member may be selected to be a Den Chief. Some units and even councils add age or rank qualifications. It works best when there is a significant age difference between the Den Chief and his charges. Also it may be advantageous to graduating Webelos if his former Den Chief is still active in the troop he joins. Try to do what is best for both the den members and the Scout.

*Since young women may be Venturing members, they also qualify to be Den Chiefs. I have used pronouns he and him throughout just because it was easier. So I apologize to all those wonderful female Den Chiefs for this slight.*

Why would one want to be a Den Chief? In a very real sense, the service qualifies as a leadership position for advancement to certain ranks. Den Chief is an official Boy Scout office and Scouts selected for this job are recognized

as troop leaders. At a personal level, the experience can be quite rewarding. Having six or ten rag-a-muffins treat you as some sort of living god once a week is good for the self-image thing. All you have to do is teach them the same games, skits and jokes that you remember doing when you were their age and WOW!!!!

When one of my own sons was a Den Chief, he formed a close relationship with the den leader and her husband. It seems that the husband worked for a lithograph works that printed covers for albums (vinyl – in those days) The walls of his room, his school text books and everything else were papered with Rolling Stones album covers. Very cool, back then.

### Den Chief Responsibilities

- The Den Chief helps lead the weekly den meeting. He arrives on time, in proper uniform.
- He assists with assigned den activities at the monthly pack meetings.
- He shares responsibility with the den leaders in all den activities, looking to them for adult leadership and inspiration.
- He meets with the den leader to plan his part of the program for the den meetings. These meetings are held regularly, at least once each month, or more often, if needed.
- He sees that the den program does not include Boy Scout activities, since such activities should be saved for Boy Scouting.
- He recognizes the denner (a member of the den, chosen by his peers) as his right-hand man by giving him opportunities to serve.
- He takes part in all training opportunities so he may become a better leader.
- Den Chiefs should receive training at a [Den Chief's Training Conference](#). They also receive continuous and regular training from the den leader and Cubmaster.

### Helping At Den Meetings

- **Gathering Period** - Helps teach boys tricks, puzzles, games, while den leader is busy checking attendance and collecting dues. The activities he uses here could be related to the monthly theme.
- **Opening** - Helps den leader organize boys and get them ready for the more serious part of the den meeting. He could hold a uniform inspection during this time.
- **Business** - He will have some good ideas for theme activities, service projects, trips, etc. Give him a chance to voice his ideas.
- **Activities** - This is when the den chief can be the most help. He is the activities assistant, leading boys in games, songs, craft projects, etc.
- **Closing** - Helps restore order and quiet for closing ceremony. He can help make announcements.
- **After Meeting** - Be sure to include him in your planning for next week and assign him specific responsibilities.



*Note: The Webelos Den Chief helps a Webelos den similarly. In addition to the suggestions above, he helps Webelos Scouts learn Boy Scout requirements for the Webelos badge and Arrow of Light Award and helps with demonstrations and teaching of activity badges, as needed.*

### Helping at Pack Meetings

- The den chief should be included in the planning for monthly pack meetings. He can help with any of the following:
- Help den leader set up displays.
- Help get the boys organized and seated.
- Help den leader during stunts or skit time.
- Helps with applause stunts and audience participations.
- Helps with den yell or song - or Activity Badge demonstration.
- Helps den leader maintain good behavior from Cub Scouts.
- Helps remove displays at end of pack meeting.
- Helps return pack meeting room to order.

**Den Chief Training** is for Scouts who wish to become Den Chiefs for Cub and Webelos Dens. Den Chief is a leadership position in the Troop. This training works best when the Boy Scout and the Cub/Webelos den leader go through the training together so that they become familiar with what he learns there. The Cubmaster of the pack should also attend, as well as any troop leadership.

Den Chief Training is, also, available on the web at <http://www.scouting.org/training/youth/denchefttraining.aspx>

### Den Chief Training Conference

This one day training experience is intended for those Boys Scouts who meet National Qualifications and would like to serve in a leadership position while giving service to brother Cub Scouts. Elements of this training include:

- Your Job As Den Chief
- How To Use and Lead Games
- How To Lead Songs
- Dual Contest and Tricks
- Working With Cub Scouts and Den Leaders
- Seven Parts of A Successful Cub Scout Den Meeting
- Five Parts of A Successful Webelos Den Meeting
- Den Chief/Webelos Den Chief Responsibilities

See *Den Chief Training Pamphlet #34450C*.

### Ways to Keep Your Den Chief Happy

- Recognize him at the first pack meeting.
- Make sure he has a Den Chief Handbook (#33211). It's full of great ideas.
- See that he has training.
- Give him important jobs.
- BE PATIENT...he's just a boy.
- Understand his limitations and abilities.
- Help him feel that he is successful.

- DO NOT leave discipline problems up to him.
- Recognize him on his birthday or other special occasion.
- Congratulate him before the den and pack when he receives a Boy Scout Rank Advancement.
- Present his Den Chief cord or badge to him at a troop Court of Honor in front his peers.

### Links

- [Den Chief Service Award. US Scouting Service Project](#)
- [You Are Boy Scouting!. Suzanne Wilson, Scouting Magazine.](#)
- [Cub Scout Den Chief: From National Council](#)
- [The Den Chief Role. Virtual Cub Leader's Handbook](#)

## SPECIAL OPPORTUNITIES

### Good Manners

[www.uscouts.org](http://www.uscouts.org)

*This subject was added in 2009.*

*This is certainly one area where a Cub Scout of any age can be responsible. That is he is always the only one responsible for his behavior!!*

### Belt Loop



### Requirements

Tiger Cubs, Cub Scouts, and Webelos Scouts may complete requirements in a family, den, pack, school, or community environment. Tiger Cubs must work with their parents or adult partners. Parents and partners do not earn loops or pins.

Complete these three requirements:

1. Make a poster that lists five good manners that you want to practice. Share your poster with your den or family.
2. Introduce two people correctly and politely. Be sure that one of them is an adult.
3. Write a thank-you note to someone who has given you something or done something nice for you.

### Academics Pin



*Earn the Good Manners belt loop, and complete five of the following requirements:*

1. Meet one new person, shake hands properly, and introduce yourself. Extend your hand, grip the person's hand firmly, and gently shake hands.

2. Talk with your family about polite language. Include "please," "you're welcome," "excuse me," "yes, sir," "no, ma'am," and so on in your talk.
3. Explain to your den or family how good manners can help you now and as you get older. Copy the actions of someone you know who has good manners.
4. Go over table manners with your family. Eat a meal together where the table is set correctly and everyone uses good table manners.
5. With an adult, discuss what foods are proper to eat with your fingers. Practice eating some of these foods the right way.
6. In your den or with your family, practice using good phone manners.
7. Explain how treating things that belong to other people with respect is a part of having good manners. Show three examples of how you can show respect for others.
8. Talk with your friends or family members about following the rules and having good sportsmanship when playing games. Then play a game with your friends or family members. After playing the game, tell how you showed good manners.
9. With your family or den, list five rules to remember in being polite and respectful when in a public place. Go to the public place and practice the rules. Explain how the rules helped you to have good manners.
10. Demonstrate the proper outfit to wear at school, at play, and at a social event.

### Boys' Life Reading Contest for 2010

<http://boyslife.org/>



**SAY 'YES' TO READING**

*Enter the 2010 Boys' Life Reading Contest*

***Have your boys do this with their Summer Reading List from School – Get two things done at the same time - CD***

Write a one-page report titled "The Best Book I Read This Year" and enter it in the Boys' Life 2010 "Say Yes to Reading!" contest.

The book can be fiction or nonfiction. But the report has to be in your own words — 500 words tops. Enter in one of these three age categories:

- \* 8 years old and younger
- \* 9 and 10 years old
- \* 11 years old and older

First-place winners in each age category will receive a \$100 gift certificate good for any product in the Boy Scouts official retail catalog. Second-place winners will receive a \$75 gift certificate and third-place winners a \$50 certificate.

Everyone who enters will get a free patch like the one shown above. *(And, yes, the patch is a temporary insignia, so it can be worn on your Cub Scout or Boy Scout uniform*

*shirt, on the right pocket. Proudly display it there or anywhere!)* In coming years, you'll have the opportunity to earn different patches.

The contest is open to all Boys' Life readers. Be sure to list your name, address, age and grade in school on the entry.

Send your report, along with a business-size, self-addressed, stamped envelope, to:

Boys' Life Reading Contest  
S306  
P.O. Box 152079  
Irving, TX 75015-2079

Entries must be postmarked by Dec. 31, 2010 and must include entry information and a self-addressed, stamped envelope.

See 2009's winners posted at -

<http://boyslife.org/home/12652/2009-boys-life-reading-contest-winners/>

For more details go to <http://boyslife.org/>

### Knots of the Month

#### Spirit of Scouting Service Awards

*Kommissioner Karl*



The "Scouting... Vale la Pena" (left) and Asian American (right) Spirit of Scouting awards recognize distinguished contributions to scouting in the Hispanic and Asian-American communities respectively. Nominees are chosen for outstanding services and demonstrated involvement in developing and implementing Scouting opportunities for Hispanic-American/Latino and Asian American youth. These are similar in scope to the Whitney M. Young Award – and are approved by the National Office's Scoutreach bureau.

Many packs and troops have opportunities to reach out to less fortunate immigrant families and bring scouting to boys that might otherwise be left behind.

If you your unit, sponsoring organization or an outstanding volunteer works hard to get these youth involved – you may go to: [http://www.bsa-gyc.org/awards/distinguished\\_service.htm#asian](http://www.bsa-gyc.org/awards/distinguished_service.htm#asian)

to print a nomination form and for more guidelines.

A brochure on the Asian Award is available here:

<http://www.scouting.org/filestore/multicultural/pdf/11-194.pdf>

The link I have for the Vale la Pena Hispanic Award does not work and I have been unable to find an application on line. If you have a link, please send it to me.

## GATHERING ACTIVITIES

*Note on Word Searches, Word Games, Mazes and such – In order to make these items fit in the two column format of Baloo's Bugle they are shrunk to a width of about 3 inches. Your Cubs probably need bigger pictures. You can get these by copying and pasting the picture from the Word version or clipping the picture in the Adobe (.pdf) version and then enlarging to page width. CD*

### Responsibility Activities

#### Dot to Dot Fire Engine

*Alice, Golden Empire Council*

Can you find the message in this Dot to Dot? It's something you should know and be ready to use responsibly!

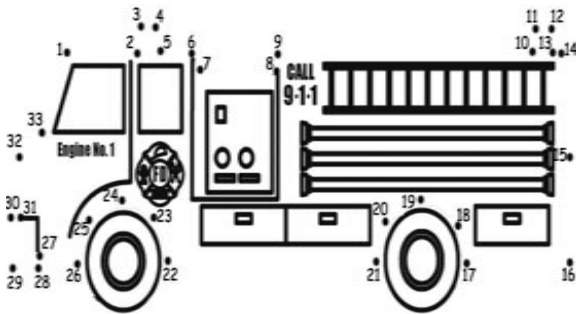

*The answer is "Call 911." Talk about how to use it, when NOT to use it, practice making pretend calls. Using 911 responsibly means that real emergencies can be handled faster.*

#### Chore Charts

*Alice, Golden Empire Council*

- ✓ **Have Pack families share their chore charts or assignment ideas in a display at pack meeting.** Teachers might also have some good tips to share with pack families and leaders. You could also have the boys share their examples of how they acted with responsibility during the month at the Brag Table.
- ✓ **Turn your Pack or Den Meeting Preparation into a Chore list and let everyone take responsibility by choosing a job to help.** Make a list of each thing that needs to be done to get the room ready: putting up displays, setting out tables and chairs, preparing the treat, setting out materials and directions for games and crafts, getting out the flags, setting up stations and/or the Brag Table and sign in table. Pair boys and boys with adults according to the task. Explain that everyone should return their job description card or check off their job when done. Point out that with everyone being responsible, the meeting is ready in record time! You can use the same idea for the end of the meeting. Who knows? It could become a welcome tradition!

#### Who Am I & What Am I Doing?

*Alice, Golden Empire Council*

Before the pack meeting, make a life-size drawing of each boy in the act of doing a chore or some kind of responsibility that he has.

Then post the silhouettes on the wall for the pack meeting and have everyone try to identify who the silhouette is and what job they are doing.

If you do this activity, you might want to use the "Who's Responsible" Opening Ceremony and refer to the silhouettes.

#### Responsibility Word Search I

*Alice, Golden Empire Council*

In this puzzle you will find each of the words listed below – each word has something to do with being responsible. As in all word searches, the words can be forwards, backwards, or on the diagonal.

```

J C I S Z C D I N K E R T I K
L D E T I K R L T L S E S F S
Q E E D U L D V B M R L E X J
O M C P O M J A A M N I N B U
W N V I E J T X L F B A O K L
R E S P O N S I B L E B H W D
L W H A U H D L Y C Z L N A J
Y T E O F L C A H V V E C C A
R M C P L A N E B D U O Y G K
J C E S I M O R P L N F Q D E
A H G Z O J P M A T E S G J I
B X O G Y N X O R Y U L I N X
R U U K O K G O F M P V U Q O
Q K W Z J I L Y T O X G X X R
U Y A P F E G Q K F Q H D A J
    
```

ACCOUNTABLE  
CONTROL  
GOAL  
PLAN  
RELIABLE

CHOICE  
DEPENDABLE  
HONEST  
PROMISE  
RESPONSIBLE

#### Aid Kits

*Alice, Golden Empire Council*

**Put together Humanitarian Aid kits, such as school kits, as families arrive.** You can use an online source for directions and information on where to take them, or check with a local charity. Go to:

[www.lds.org/library/page/.../0,7098,6433-1-3298-1,00.html](http://www.lds.org/library/page/.../0,7098,6433-1-3298-1,00.html)

#### What does Webster say??

*Alice, Golden Empire Council*

**In honor of Noah Webster's Oct. 16 birthday, have a selection of different dictionaries and thesauruses available** - and ask everyone to look up Responsibility or find a word that can be used in its place. You could team families or dens together and see which team can come up with the most options and definition

**Responsibility Word Search II**  
*Catalina Council*

S E L F C O N T R O L E E A Z  
I A R U R W H Q R H C R N Q B  
D W C Y F O H E D N D E I G D  
U O M C N S T O A E Q L L O E  
T S V E O C S R P L Q I P A T  
I E S Y A U E E O B V A I L T  
X T H R N V N G C F X B C S I  
Y S A K E D R T U C F L S E M  
A H D S A A P G A R U E I T M  
C C R B P V O V I B B S D T O  
R E L S E C I O H C L H F I C  
P E V I T A I T I N I E L N U  
J X I C B Y A P A F A L E G I  
Z U E F F U M M Y D G K S C H  
I N T E G R I T Y V N L N T D

- |              |                 |
|--------------|-----------------|
| ACCOUNTABLE  | CHOICES         |
| CHARACTER    | COMMITTED       |
| COMMENDABLE  | EFFORT          |
| GOAL SETTING | HONESTY         |
| INITIATIVE   | INTEGRITY       |
| PERSEVERANCE | RELIABLE        |
| SELF CONTROL | SELF DISCIPLINE |
| SUCCESSFUL   |                 |

**Responsibility Posters I**  
*Catalina Council*

Using poster board or other paper have the boys make a chore chart that they can use at home. Provide markers and stickers for the boys to decorate their charts. Below is an example of a chart with some ideas on it.



## Chore Chart

My weekly chores	Days						
	Sun	Mon	Tue	Wed	Thurs	Fri	Sat
Make bed							
Clean room							
Brush teeth							
Care for pet							
Set table							
Help with dishes							
Do homework							
Help Mom & Dad							
Take out trash							

**Responsibility Posters II**  
*Catalina Council*

Print out the phrases below and have the kids glue them to construction paper and decorate them to make their own responsibility posters.

**Phrase #1:**

- ✓ If we want peace, we have the responsibility to be peaceful.
- ✓ If we want a clean world, we have the responsibility to care for nature.
- ✓ Responsibility is doing your share.
- ✓ Responsibility is carrying out duties with integrity.
- ✓ When one is responsible, there is the contentment of having made a contribution.
- ✓ As a responsible person, I have something worthwhile to offer—so do others.
- ✓ A responsible person knows how to be fair, seeing that each gets a share.
- ✓ With rights there are responsibilities.
- ✓ Responsibility is using our resources to generate a positive change.

**Phrase #2:**

- ✓ Responsibility is doing my job.
- ✓ Responsibility is caring.
- ✓ Responsibility is trying my best.
- ✓ Responsibility is doing my share of the work.
- ✓ Responsibility is taking care of things.
- ✓ Responsibility is helping others when they need help.
- ✓ Responsibility is being fair.
- ✓ Responsibility is helping to make a better world.

**Responsibility Posters III**  
*Catalina Council*

Have the boys create their own responsibility poem with the letters from the word.



Name: \_\_\_\_\_

### Responsibility Poem

R is for \_\_\_\_\_

E is for \_\_\_\_\_

S is for \_\_\_\_\_

P is for \_\_\_\_\_

O is for \_\_\_\_\_

N is for \_\_\_\_\_

S is for \_\_\_\_\_

I is for \_\_\_\_\_

B is for \_\_\_\_\_

I is for \_\_\_\_\_

L is for \_\_\_\_\_

I is for \_\_\_\_\_

T is for \_\_\_\_\_

Y is for \_\_\_\_\_

**Responsibility Ladder**

Alice, Golden Empire Council

Fill in a "Responsibility Ladder" during the month to display at the Pack Meeting. Each boy can work on his own ladder to display.

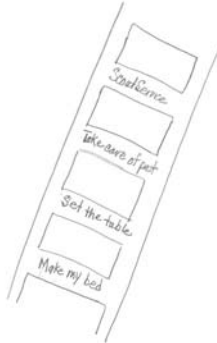

Kids at one school came up with their own ideas of what it means to be responsible, and then shared them on a ladder. The ladder was meant to show that as you take responsibility for one thing, you become even more responsible. Practice makes perfect! For more ideas, go to:

[www.intime.uni.edu/.../Responsibility%20\(Mar\)/responsibility05.htm](http://www.intime.uni.edu/.../Responsibility%20(Mar)/responsibility05.htm)

**Disability Awareness**

Alice, Golden Empire Council

Celebrate Disability Awareness Month by having different stations where "Ethics in Action" type activities can be done. Check Disability Challenges under the Games Section for some additional ideas.

**Food Activities**

**Word Search**

Great Salt Lake Council

S U P G A R C M C D E S S E R T  
 R I S C E M V E E G A E T A B L  
 E S U P P E R S R P T A S R A F  
 R U G I T A L U E S N C H B H R  
 P E A A K T F P A S T A S T C A  
 O F R I C E I F L O U R S H I S  
 U A N D L U K N C H D C I N W N  
 L E R C H A C E S E S H E G D S  
 T F I V E G E T A B L E S G N E  
 R L F R U I T O L U R E L U A N  
 Y C B H S L A T T F I S H S S U  
 P L U N C H P E R V E E G G S T  
 A B L E S C D I N N E R V E G D

Find the following words in the puzzle that relate to food:  
 BREAKFAST FISH RICE CEREAL  
 FLOUR DESSERT CHEESE FRUIT  
 SANDWICH SALT LUNCH SUGAR  
 DINNER MEAT SUPPER EAT  
 PASTA VEGETABLES EGGS POULTRY

**Baker's Dozen**

San Gabriel Valley-Long Beach Area-Verdugo Hills Councils  
 After you read the clues, fill in the blanks before or after this baker's dozen of baked goods.

1. Win the prize \_\_\_\_\_ cake
2. Scottish plaid \_\_\_\_\_ tart\_\_\_\_\_
3. Package \_\_\_\_\_ bun \_\_\_\_\_
4. Old Spanish pesos  
 pie\_\_\_\_\_
5. Livelihood bread \_\_\_\_\_
6. Fried pastry \_\_\_\_\_ dough\_\_\_\_\_
7. Young rabbit \_\_\_\_\_ bun\_\_\_\_\_
8. Full width \_\_\_\_\_ bread\_\_\_\_\_
9. Showy dance step \_\_\_\_\_ cake\_\_\_\_\_
10. Elevated amusement park railway  
 roll\_\_\_\_\_
11. Baker's utensil \_\_\_\_\_ roll\_\_\_\_\_
12. Lazy person \_\_\_\_\_ loaf\_\_\_\_\_
13. Person or thing of excellence cracker\_\_\_\_\_

**Answers**

Take the cake, tartan, bundle, pieces of eight, bread and butter, doughnut, bunny, breadth, cakewalk, roller coaster, rolling pin, loafer, crackerjack

**Kitchen Anagrams**

San Gabriel Valley-Long Beach Area-Verdugo Hills Councils  
 Add the letter shown after each word, and then rearrange the letters to spell the names of items that can be found in the kitchen.

1. soon + p = \_\_\_\_\_
2. beat + l = \_\_\_\_\_
3. low + b = \_\_\_\_\_
4. sags + l = \_\_\_\_\_
5. fine + k = \_\_\_\_\_
6. tale + p = \_\_\_\_\_
7. kin + s = \_\_\_\_\_
8. loot + s = \_\_\_\_\_
9. vest + o = \_\_\_\_\_
10. hid + s = \_\_\_\_\_
11. lap + I = \_\_\_\_\_
12. cause + r = \_\_\_\_\_

**Answers**

1) spoon 2) table 3) bowl 4) glass 5) knife 6) plate 7) sink  
 8) stool 9) stove 10) dish 11) pail 12) saucer

**In the Refrigerator**

Russ, Timucua District

What's one of a Cub Scout's favorite scouting places, but "in the refrigerator"? Give out sheets of paper that have "in the refrigerator" across the top. Then have everyone try to get as many words as possible from the letters. What should happen to the winner, but a trip to the refrigerator and an ice cream certificate!

**Vegetable Letter Square**

*San Gabriel Valley-Long Beach Area-Verdugo Hills Councils*  
Find the following vegetables below by reading forward, up, down, and diagonally. Then read the leftover letters to discover what a vegetable truck would get if it went over a big bump!!!

Asparagus	Avocado	Beans	Beet
Brussels Sprouts	Carrot	Cauliflower	Celery
Corn	Cucumber	Eggplant	Lettuce
Mushroom	Okra	Onion	Peas
Pepper	Potato	Spinach	Squash
Tomato	Turnip	Yam	Zucchini

A E G G P L A N T S P I N A C H A B  
 S M U S H R O O M L E T T U C E C E  
 P E A S P O T A T O P H U T G E U E  
 A B R U S S E L S S P R O U T S C T  
 R C E L E R Y A M T E O B R O Q U O  
 A S O N I O N S E D R S E N R U M M  
 G A K R Z U C C H I N I A I R A B A  
 U L R A N A V O C A D O N P A S E T  
 S C A U L I F L O W E R S D C H R O

**Taste Test**

*Russ, Timucua District*

This is a takeoff on Kim's Game and is done using the sense of taste. Premix a dozen different flavors in liquid form and have them in small sampling jars (like mason jars or baby food jars. Flavors can include extracts (like vanilla and almond), drink flavors (like cherry and grape juices), diluted vinegar, etc. Place the flavors at numbered stations and hand out cards with the numbers next to blank lines. Also have toothpicks (many of them) at each station so that each person can use a different toothpick at each station. Let everyone try each flavor and try to identify as many as they can. The winners are those that identify the most flavors. As rewards for all the valiant efforts, give everyone flavored tootsie rolls or lollypops.

**Fire Activities**

**Hometown Hero Matching Game**

*Timucua District, North Florida Council*

Hang up pictures of famous "hometown Americans" with their names below their pictures. (These can be US heroes, locals, etc.) Have their heroic deeds listed out on a sheet that is handed out to everyone and have folks match the people with the actions.

**Connect the Dots**

*Timucua District, North Florida Council*



**To the Rescue Word Search**

*San Gabriel, Long Beach Area, Verdugo Hills Councils*

W T B T C E L P D Q T O R Y I Q J H R G  
 D E E X N A Q R L E F E S C R L Q E N Q  
 F R V L J A A B M E H J E N A E D L S T  
 C I A R E U R L C S H S A E R T S I R J  
 D O R U G P E D I W R T T G E B K C D J  
 C U O E G H H U Y N P N B R C W J O U N  
 S G F K E G G O C H C E E E I H T P P E  
 V I I I X N N V N X E R L M F S C T L N  
 L Y B A I W G I Z E Y A T E F A U E T G  
 V F E T U Q P I S B E P M L O F Z R Q R  
 Q U X Q S L P S N S O C I G E E N E P D  
 J E L A D D E R N E O F N Z C T V X I H  
 R F I R E F I G H T E R S A I Y X L O L  
 P A R A M E D I C J L G C P L S P S L P  
 N E R I S M J A A W G X D U O U E X X N  
 T Z Y U E G R C P P J A U B P S B L T T  
 S Z Z W E S K M R A L A E K O M S M L H  
 E T E Q E E S R O T C O D P M P A Y A E  
 K E T A T Z L V U D K W E V C Y R I T L  
 D S T T H G H K Q T Q C J X A U S H Q A

Find words that describe rescue workers, their tools and safety items printed in the word search above. They can be upside down, backwards, forwards or diagonal.

- |                |              |                |
|----------------|--------------|----------------|
| AMBULANCE      | CAR SEAT     | CPR            |
| CROSSING GUARD |              | DOCTORS        |
| EMERGENCY      | EXTINGUISHER | FIRE ENGINE    |
| FIREFIGHTERS   | HELICOPTER   | HELMET         |
| HELP           | HOSES        | HYDRANT        |
| LADDER         | LIFEGUARD    | LIFEJACKET     |
| PARAMEDIC      | PARENTS      | POLICE OFFICER |
| RESCUE         | SAFETY       | SEATBELT       |
| SIREN          | SMOKE ALARM  | TELEPHONE      |

**Fire Safety Quiz**

*Timucua District, North Florida Council*

Use this at a den meeting by reading the questions and asking the boys to write down the letter of the correct answer, or by making copies and giving one to each boy.

- What should you do to be ready if fire should strike your home?
  - Keep pails of water handy.
  - Have an escape plan and rehearse it often.
  - Be ready to carry out furniture.
  - Have a suitcase already packed.
- In making your escape plan, why should you know two ways out of every room?
  - So I can see different parts of the house when I practice.
  - In case fire or smoke blocks one escape route.
  - To keep people guessing.
  - To make home fire drills more fun.
- If your clothing catches fire, what do you do?
  - Run for help.
  - Look for water to throw on yourself.
  - Roll on the floor or ground, wrapping yourself in a coat, blanket, or rug, if possible.
  - Try to blow out the fire.
- What should you use for light in a dark closet where there is no light bulb?
  - A match.
  - A candle.
  - A cigarette lighter.

- d. A flashlight.
5. When you check extension cords in your home for fire hazards, what should you look for? Choose two.
- Frayed, broken insulation.
  - Whether the color matches the woodwork.
  - Whether they run under rugs.
  - Whether the plug is brown or white.
6. If there are small children in your home, you should be especially careful that they cannot play with which of these?
- Pile of blankets
  - Matches
  - Tennis Balls
  - Pots and Pans
7. In checking around a furnace for fire hazards, you should remove which of these?
- Fishing rods and reels.
  - Table.
  - Garden Tools
  - Gasoline can, greasy rags, newspapers
8. Stairways in your home should be:
- A great place to play.
  - A good place to keep your toys when you aren't playing with them.
  - Kept clear of obstructions at all times.
  - A place to pile your laundry until you can take it to your room.

Answers: 1-b, 2-b, 3-c, 4-d, 5-a-c, 6-b, 7-d, 8-c

## Sports Activities

### Blind Man's Ball

*York Adams Area Council*

- ℞ Gather five or so different sports balls.
- ℞ For each one, get a large enough covered box into which the ball will fit.
- ℞ Cut hand-holes in the side of each box and cover the holes with "curtains" so the players can't see into the box.
- ℞ Label the boxes for identification (e.g., 1, 2., 3. etc.).
- ℞ Have each person feel the ball in the box and figure out what type it is.

### Team Logo Geography Quiz

*York Adams Area Council*

- ℞ Post logos from various professional sports teams.
- ℞ Have an answer sheet for people to write down the home city for the team

or

- ℞ Make a match game with logos in one column labeled as A to ??, and cities in the other column as 1 to ??
- ℞ Have the people match up the pairs.

*Be careful not to use logos that give away the city  
The Dodgers may be too easy - But the Orioles might work*



## Gathering Activity

*Crossroads of America*

Set the room up with stations so the boys can do a different fitness event at each station as they wait for the opening.

### Earth Ball

*Sam Houston Area Council*

- ★ Using a beach ball the group task is to hit the "Earth" ball, keeping it in the air without letting it touch the ground.
- ★ Additionally, no Scout can touch the Earth ball twice in a row.
- ★ Set a goal with the group for the number of hits that the group can make following the rules.

## DRIVEWAY OR PARKING LOT BASEBALL

*Great Salt Lake Council*

Draw a simple baseball field (not just diamond) on the ground with chalk. Mark different colored circles in various areas of the field. Each color would indicate a type of hit: single, double, triple, or home run.

To play, the player kneels or stands at home plate and tosses a stone into a circle. If he misses it's an out. If it lands in the circle the other team can try to toss their stone into the same circle. If the second team makes it into the same spot it's an out, if not the first team gains the number of bases listed by the spot. After three outs the teams switch sides.

## SOCCER BOWL

*Great Salt Lake Council*

Set up 10 cans in the grass. Players kick a soccer ball at the cans to try and knock as many down as they can from 20 feet away.

## OUTDOOR CHECKERS

*Great Salt Lake Council*

Use chalk to mark out a large checkerboard and use colored plastic plates for the checkers. As boys arrive they can join a side and work as a team to win the game.

## ABILITY AWARENESS

*Great Salt Lake Council*

Provide a wheel chair, blindfolds, crutches and arm slings to debilitate the boys. Provide obstacles for them to accomplish in their new state of being.

## PHYSICAL SKILLS

*Great Salt Lake Council*

Compete in the physical feats required for each rank. Crab walk, high jump, two-man games, etc.

## TABLETOP HOCKEY

*Great Salt Lake Council*

Cut a plastic berry container or something similar, in half vertically. Invert one half of the container and set it at one end of a table. Cubs can line up at the opposite end and try to score by flicking "button pucks" into the net.

## STICKS AND STONES (Native American)

*Great Salt Lake Council*

Take 3 popsicle sticks and color one side black. Players then drop their sticks on the ground and score based on the number of black sides that are up. This can also be done with flat rocks by marking one side with a marker.

**SPORTS SCRAMBLE**  
*Great Salt Lake Council*

Write the letters of common sports onto colored paper. Cut the individual letters apart and scramble. Have the boys unscramble the letters.

**Bike Activities**

**Wheeling Into Summer Word Search**  
*Alice, CS RT Commissioner*

*Pioneer District, Golden Empire Council*

Find the words below that have to do with Wheels – they may be up or down or on the diagonal.

S L E E H W L B A M M I J W S  
 G I W H L O S V I H J O P S E  
 O Y K R O F Q A C C H E T C T  
 W V G K Q D L C F V Y R I O A  
 P U N C T U R E U E A C L O K  
 S L A N G I S T L F T I L T S  
 T D Y L N K E D F E S Y R E U  
 T H A I G K D I O T K K N R M  
 J E A N C A C T E A S O R Q M  
 K H M O S T P N L H N E P F E  
 C N R L B R A K E S G V R S R  
 W P E H E P D U X Y I I U I T  
 S E O E L H S A Y D S N P F T  
 L F V V V X Q Y E B F B J E C

- |          |         |        |
|----------|---------|--------|
| BICYCLE  | BRAKES  | CHAIN  |
| FORK     | HELMET  | KNEE   |
| LISTEN   | LOOK    | PADS   |
| PUNCTURE | SADDLE  | SAFETY |
| SCOOTER  | SIGNALS | SIGNS  |
| SKATES   | SPARE   | SPOKE  |
| SPROCKET | SUMMER  | TIRE   |
| TRAFFIC  |         | WHEELS |

**Helmet Maze**

<http://www.bhsi.org> :

Find your way through this maze to connect the helmet with the bicycle.

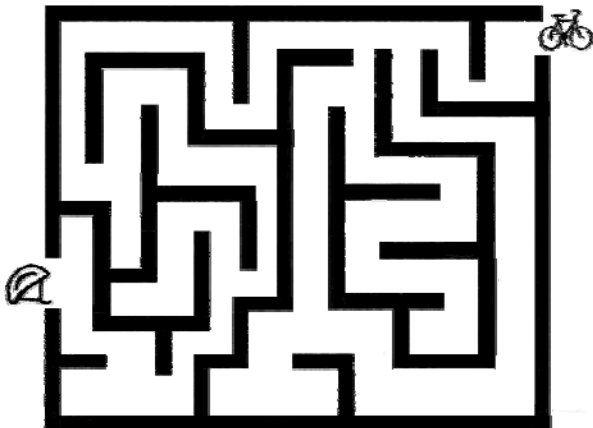

**One Smart Cat Says**

[www.bhsi.org](http://www.bhsi.org)

Connect the dots to see what O.S. Cat wears every time he rides a bike



**Bike Check:**

*Alice, CS RT Commissioner*

*Pioneer District, Golden Empire Council*

Have everyone bring their bikes and check for proper size, good brakes; make adjustments and repairs. (This is a great way to start off a Bike Rodeo)

**Which Wheel Am I?**

*Alice, CS RT Commissioner*

*Pioneer District, Golden Empire Council*

As people arrive at the Pack Meeting, tape one of the following on their back, without them seeing the name: Bicycle, Skateboard, Scooter, Inline Skates. Each person must locate others in the same name group by asking only Yes or No questions – or by making a noise that represents the wheel group they're in.

**What is it?**

*Alice, CS RT Commissioner*

*Pioneer District, Golden Empire Council*

Mount an unlabeled picture of a bike on the wall – number each part of the bike, or block out the labels on a labeled picture. As they enter, each person or family gets a sheet with a list of the parts of a bike. They must decide which number goes with the part on their list. Winner is the one with the most correct answers when the meeting starts.



## OPENING CEREMONIES

### Who's Responsible?

Alice, Golden Empire Council



#### Materials:

Life size silhouette drawings of scouts doing different chores and jobs that they are responsible for (have each boy lay down on large paper such as a roll of paper meant to cover tables, then draw around him as he takes the appropriate position to be doing a chore)

You could also use stock silhouettes showing people doing various chores and jobs. **Note:** For an extra challenge, you can give everyone a numbered list that corresponds to a number by each figure –

As a Gathering Activity, people take their list and a pencil and try to identify the silhouette and what they're doing. Answers and winning audience member is not identified till the Opening is all done.

**Cubmaster or Narrator:** This month, the boys have been practicing being responsible. We thought it might be fun to see if you can recognize who is being responsible, and what they are doing. Let's look at our first riddle. (*Points to one of the figures*) Who's being responsible here? (*Let audience guess – when they guess the right person, call that boy forward*) OK, \_\_\_\_\_, we know this is you being Responsible. Do you think anyone will guess what job you're actually doing?

*(Narrator takes guesses from the audience, checking with the scout each time to see if the answer is right – when the correct guess is made, the scout can explain what his job is, when he does it and how often.)*

**Boys could each have their response written out if they want, or narrator can just guide the answers from the scout with questions.**

**Narrator:** Well, thanks \_\_\_\_\_. We can certainly see that you are trying to be responsible and do your chores!

*This continues till each silhouette has been identified, along with their job.*

**Narrator:** Well, as you can see, our Scouts are learning to be responsible. There's another responsibility that we learn about in Scouting – the responsibility to be a good citizen and honor our country's flag. (*Begin Flag Ceremony*)

#### Follow, Helps, Gives Opening

Catalina Council

**Cub #1:** A Cub Scout Follows Akela  
He always does his best  
To be helpful, kind and giving  
And as a citizen pass the test.

**Cub #2:** A Cub tries to Help others  
In some way every day

At home, at school, anytime  
And in any helpful way.

**Cub #3:** A Cub Scout Gives to others  
His talents, time and goodwill  
He shares, he cares, he is happy  
And makes others happier still.

**Cub #4:** A Cub Scout is a special person  
Who Follow, Helps, and Gives  
He sets a good example  
As he touches many lives.

**Cub #5:** He is growing, learning, trying  
To be the best he can  
As he follows, helps and gives  
He learns to be a special man.

**Cub #6:** He is and always will be  
A Super Leader  
When he follows, helps and gives.  
Please follow me in the Pledge of Allegiance.

## AUDIENCE PARTICIPATIONS

### Cub Scout Heroes

Catalina Council

Divide the group into four smaller groups and assign each group one of the words listed below. Practice as you make assignments. Read the story.

After each of the words is read pause for the group to make the appropriate response.

**FOLLOW:** A Cub Scout Follows Akela (Give sign)

**HELP:** The Pack Helps the Cub Scout Grow (Give sign)

**GIVE (GAVE):** A Cub Scout Gives Goodwill (Give sign)

**PACK:** A Cub Scout Helps the Pack Go (Give sign)

**CUB SCOUT:** ALL give the Cub Scout signs and say, "Do Your Best."

**HERO (HEROES):** All adults cheer "Hip, hip hooray!"

This is the story of Gary, a **CUB SCOUT** who wanted to do something to **HELP** his elderly neighbor, Mrs. Green. This **CUB SCOUT** wanted to **FOLLOW** the advice of his **PACK** leaders, who asked every **CUB SCOUT** to find some way they could **GIVE HELP** to someone else. Gary thought that his neighborhood would be the best place to start. One way Gary could think of to **HELP** his neighbor was to rake up the leaves in her yard for her. It was such a big yard, though, and he was such a little **CUB SCOUT**. Gary needed some **HELP**.

So he thought some more and decided to talk to his **PACK** leaders and see if they could **GIVE** him some suggestions. The **PACK** leaders said they would ask if any other **CUB SCOUTS** would like to **FOLLOW** Gary's example and **HELP** rake the leaves for Mrs. Green. What started with only one **CUB SCOUT HELP**ing Mrs. Green soon grew to two **CUB SCOUTS**, then three **CUB SCOUTS**, then four **CUB SCOUTS**, then five **CUB SCOUTS**... (Continue adding **CUB SCOUTS** while the audience **GIVES** the **CUB SCOUT** sign each time and says "Do Your Best!" until everyone starts to laugh. Then finish reading the story.)

Mrs. Green told everyone about Gary and his **CUB SCOUT PACK**. She called the **CUB SCOUTS** her **HEROES** because of all the **HELP** they **GAVE** her. The moral of this story is: If you **FOLLOW** the advice of your **PACK** leaders, and **GIVE HELP** to those around you, you will be a great **CUB SCOUT**, and maybe someone's **HERO**, too.

**The Litterbug**  
*Catalina Council*

Divide the group into four smaller groups and assign each group one of the words listed below. Practice as you make assignments. Read the story.

After each of the words is read pause for the group to make the appropriate response.

- |           |                 |
|-----------|-----------------|
| PAPER     | Crackle-Crackle |
| TRASH     | Dump-Dump       |
| CANS      | Clatter-Clatter |
| LITTERBUG | Toss and Throw  |

God put bugs in this world for many reasons. He made them to live in every kind of season. But the pesky **LITTERBUG** with his **PAPER** and **CAN**, was made through neglected **TRASH** by the foolish person.

To keep America beautiful, get rid of the **LITTERBUG**, so beach goers **CAN** again lounge on a clean sandy rug. Because of this pest, we must woller around, In **PAPER** and **CANS** and **TRASH** all over the ground.

Just who are these **LITTERBUGS** who mess up our land? Do you ever really see them toss that **PAPER** and **CAN**?

Quite often the **LITTERBUG** is a sneaky guy, and at dumping his **TRASH** he's oh so sly.

So most of the time it just appears everywhere. As if it had dropped right out of thin air. Could it be we are so used to throwing things here and there, that we dump that **PAPER** and **CAN** without being aware?

Without even thinking when we toss **TRASH** and waste, we could be an unconscious **LITTERBUG** in all our haste. So when you unwrap that gum or small piece of **CANdy**, don't throw the **PAPER** on the ground just 'cause it's handy.

Next time stop and think when a pop **CAN** you toss, cause if you're a **LITTERBUG**, it's also your loss. So if every single person would take note of his habit, that pesky **LITTERBUG** we could certainly nab it.

Then that terrible bug we would surely stamp out, with no more **PAPER** or **CANS** or **TRASH** about. To keep America beautiful, we must all do our part, by taking care of our **TRASH** properly from the very start.

**ADVANCEMENT CEREMONIES**

**What's the Message?**  
*Alice, Golden Empire Council*



**Materials:** If you used the "boy silhouette" idea above, you can add a colored square of paper near each one, with a large question mark on it. Attach the awards for each boy in a plastic bag behind "his"

question mark or simply list his awards on the reverse side.

**Cubmaster:** You've already seen that the scouts have been very responsible this month. Well, they've been taking **RESPONSIBILITY** for some other things as well – Advancements, Activity Pins and Belt Loops. And there's a **QUESTION** about which awards each boy should receive. But I think the scouts themselves can help us find the right answer!

*Cubmaster calls up each boy and his parents, then asks the boy to see if there's an answer to be found behind the question. The Cubmaster presents the awards with a short description of what they each mean. If everyone has won a particular award, such as a patch for a recent activity, All those patches could be behind a separate*

*"Question Mark" – to be given to everyone at the same time. Note: If you have special awards, such as Arrow of Light, Religious Awards or others, put extra "Question Marks" next to that boy's silhouette – be sure to leave special awards till the end and give them added importance.*

**Cubmaster:** Well, we've answered each question. We've found the answers. But the real answer is that the boys in Pack \_\_\_ have taken responsibility for **DOING** their **BEST!** Let's give them all a cheer!

**Civic Minded Ceremonies**  
**(Help teach Civic Responsibility)**  
*Catalina Council*

Collect bunches of old unused keys and tie them to ribbons for awards. (You may be able to get throwaways from a hardware store that grinds them.) Also have some long ribbons tied in the center with beautiful bows. Have a small shovel and a box or bucketful of dirt. Explain to the Pack the tradition of the Mayor bestowing on honored guests and dignitaries a "Key to the City". Also in other civic ceremonies the Mayor and others attend ground breaking and ribbon cutting ceremonies, and tonight the Cub Scouts earning awards and rank advancements will be the honorees at the Pack's Civic Ceremonies.

The Cubmaster acts as the Mayor (he may want to wear a top hat or sash) and announce the contributions each boy being recognized has made to the Pack. These include but are not limited to participating in pack events, in den meetings, advancing in rank etc. The Cubs and their parents are then invited to "break ground" to make way for the Cub to begin on a new section of the Scouting trail, or they may be asked to "Cut the ribbon" as they pass into the next rank or den. You may wish to bestow a "Key to the Pack" for a particularly good job or having reached a difficult goal. There are other civic ceremonies not mentioned here that may be adaptable to the presentation of Pack awards, like winning an election or being a grand marshal in a parade. Use this as a guideline and have your committee think of others.

## SONGS

### Responsibility Songs

#### Responsibility

*Alice, Golden Empire Council  
(tune: Supercalifragilistic...song)*

*(Note from Alice – When you are spelling out the word, if you sing the letters IB and IT together, it will fit the tune)*

R..E..S..P..O..N..S..I..B..I..T ..and Y

That's a way of acting with a worth you cannot buy  
If you always do the thing you promised you would do,  
Others will appreciate and always count on you!

When you see a job to do and finish what you start,  
You will be responsible and always do your part,  
People will depend on you and welcome you each day  
When you are responsible and do just what you say!

If you have been working and have left a messy place  
Don't forget the job's not done – and it's YOUR mess to face!  
Don't wait till someone tells you there's a job that must be done,  
Just turn around and do it, and you'll soon be having FUN!

**OOOOH...**

R..E..S..P..O..N..S..I..B..I..T ..and Y

That's a way of acting with a worth you cannot buy,  
If you always do the thing you promised you would do,  
Others will appreciate and always count on You!

#### The Smoke Alarm Went Off

*Alice, Golden Empire Council  
(tune: The Farmer in the Dell)*

The smoke alarm went off  
The smoke alarm went off  
It's warning you though you can't see  
The smoke alarm went off  
You'll hear the loud beep — beeps  
You'll hear the loud beep — beeps  
It smells the smoke, it's not a joke  
You'll hear the loud beep — beeps  
If you see smoke, get low  
If you see smoke, get low  
It's cool and clear down near the floor,  
If you see smoke get low  
You need to go outside  
You need to go outside  
The meeting place will keep you safe  
You need to go outside  
Now don't go back inside  
Now don't go back inside  
Just stay and wait and you'll be safe,  
So don't go back inside.

### Food Songs

#### From the Cub Scout Song Book:

There are some great food related songs for this theme in the Cub Scout songbook -

It's Cheese  
I'm A Nut  
I Like to Eat  
Johnny Appleseed

#### Bananas, Coconuts And Grapes

*Baloo's Archives*

*This song is often referred to as the "Cub Scout National Anthem." But I would vote for "Duke of York." CD*

I like bananas, coconuts and grapes  
I like bananas, coconuts and grapes  
I like bananas, coconuts and grapes  
That's why they call me: **TARZAN OF THE APES!**

Sing the song through three or four times:

The first time loudly;  
The second time softer  
*(except for the "Tarzan" part – always YELL that)*  
The third time even softer  
And finally whispering

Remember, always yell the "Tarzan" part; the last time, no one makes a sound until all shout in unison, "TARZAN ..."

#### Ravioli

*Camp Hinds Songbook*

<http://home.maine.rr.com/jhall80/alumni/resource/songbook>

Tune – Alouette

*I always sing this with Rigatoni, so don't be afraid to use your favorite four syllable pasta when you lead the song CD*

#### Chorus:

Ravioli, I like ravioli  
Ravioli, It's the best for me!

**Leader:** Do I have it on my shirt?  
*Point to garment*

**Group:** Yes you have it on your shirt.

**Leader:** On my shirt?

**Group:** On your shirt !

**All:** **Oohh Oohh Oohh Oohh.....**

#### Chorus

**Leader:** Do I have it on my shorts?  
*Point to garment*

**Group:** Yes you have it on your shorts.

**Leader:** On my shorts?

**Group:** On your shorts !

**Leader:** On my shirt?

**Group:** **On your shirt !**

**All:** **Oohh Oohh Oohh Oohh.....**

**Keep building as you add in:** socks, shoes, neckerchief, hat, or whatever garments you want  
(Remember, you are leading Scouts!)

#### Last Verse

**Leader:** Do I have it all over?  
*Point to garment*

**Group:** Yes you have it all over.

**Leader:** All Over?

**Group:** **ALL OVER!** Yell Loudly – song ends

**Gopher Guts***Baloo's Archives*

Great green gobs of grimy greasy gopher guts  
Mutilated monkey meat, little birdies' dirty feet  
Great green gobs of grimy greasy gopher guts  
And I forgot my spoon!

*There are many, many versions of this on the web. Mine is one of the better ones. But if it isn't the way you remember singing it, look for others. Just google, "Gopher Guts." CD*

**Fast Food Song***Baloo's Archives***You definitely need the actions for this one!! CD**

A Pizza Hut, a Pizza Hut  
Kentucky Fried Chicken, and a Pizza Hut  
A Pizza Hut, a Pizza Hut  
Kentucky Fried Chicken, and a Pizza Hut  
McDonald's, McDonald's  
Kentucky Fried Chicken, and a Pizza Hut  
McDonald's, McDonald's  
Kentucky Fried Chicken, and a Pizza Hut  
A Burger King a Burger King  
Long John Silvers and a Burger King  
A Burger King a Burger King  
Long John Silvers and a Burger King  
Red Lobster Red Lobster  
Long John Silvers and a Burger King  
Red Lobster Red Lobster  
Long John Silvers and a Burger King  
Dairy Queen A Dairy Queen  
Chucky Cheese and a Dairy Queen  
Dairy Queen A Dairy Queen  
Chucky Cheese and a Dairy Queen  
Roy Rogers Roy Rogers  
Chucky Cheese and a Dairy Queen  
Roy Rogers Roy Rogers  
Chucky Cheese and a Dairy Queen

**Actions:****Pizza Hut** - Make shape of a hut in the air**Kentucky Fried**- Flap elbows up and down in the manner of a demented chicken**McDonalds** - Put hands on top of head and bridge out and down to produce the "Golden Arches"**Burger King** - Hands on head with fingers up for a crown**Long John Silver** - mimic sword play**Red Lobster** - hold up arms and bring fingers down on thumbs like lobster claws snapping**Dairy Queen** - mimic milking a cow**Chucky Cheese** - mimic throwing up a pizza**Roy Rogers** - mimic riding a horse**Hot Dog Song***Baltimore Area Council*

Tune: Oscar Meyer Wiener Song

I wish I was *a fat* and juicy hot dog,  
That is what I'd truly like to be.  
'Cause if I were *a fat* and juicy hot dog,  
Someone'd always be in love with me.

*Have the leader keep this going by calling for everyone to sing it louder, then faster. Then as if your mouth was full .*

**On Top Of Spaghetti***San Gabriel Valley-Long Beach Area-Verdugo Hills Councils*

Tune: On Top of Old Smokey

On top of Spaghetti,  
All covered with cheese  
I lost my poor meatball  
When somebody sneezed  
It rolled off the table  
And on to the floor  
And then my poor meatball  
It rolled out the door.  
It rolled in the garden  
And under a bush  
And now my poor meatball  
Is nothing but mush?  
So if you have spaghetti  
All covered with cheese  
Protect your poor meatballs  
Should somebody sneeze?

**Peanut, Peanut Butter, Jelly***San Gabriel Valley-Long Beach Area-Verdugo Hills Councils***You need to experience this song before you try to lead it.****The actions and sounds are a large part of this one. CD****CHORUS:**

Peanut, Peanut butter, jelly

Peanut, Peanut butter, jelly

First you take the peanuts and you crunch them, crunch them  
(Chorus)

Then you take the grapes and you stomp 'em, stomp 'em,  
(Chorus)

Then you take the bread and you spread it, spread it,  
(Chorus)

Then you take the sandwich and you eat it, eat it,  
(Chorus)

**Fire Songs****9-1-1 HELP***Greater St. Louis Area Council*

Tune "My Bonnie"

Emergencies they will answer,  
They're always a phone call away  
They come when they're needed most promptly  
And for you they will most surely stay

**Chorus:**

Nine-one-one

Nine-one-one

We call on them when we need HE...LP

Medics are your friends and my friends  
They answer their calls so fast  
They come when they are needed so greatly  
And always will stay to the last.

**Chorus:**

The firemen too answer calls  
A fire is scary to see  
But when they come oh so quickly  
They put out the fire with glee

**Chorus:**

We often need a policeman  
And 9-1-1 will get one there  
Be sure that you know your address  
Of this you should always be aware

**Chorus:****Fireman's Song**

*Timucua District, North Florida Council*

*(No tune was listed in either spot I found this song. So  
make one up or if you know – E-mail me. CD)*

Behold the noble Fireman, all dressed in red and black.  
He climbs the tilted ladder with a rope upon his back.  
An axe he carries by his side, a helmet on his head,  
He goes to fight the fire, most powerful and dread.  
He is our unsung hero, this man of brawn and might,  
And to watch him fight a fire is a great and wondrous sight.

**Fire Prevention**

*Baltimore Area Council*

Tune: Clementine

Check your hallways, check your closets,  
And underneath the stairwell, too.  
For if you've piled lots of junk there,  
A big fire may call on you.

Dirty paint rags, piled up papers,  
Frayed extension cords won't do.  
Fire prevention is the answer,  
All cub Scouts must follow through.

**Prevent Fires**

*Baltimore Area Council*

Tune: Are you Sleeping?

Prevent fires, prevent fires,  
Do your part, do your part,  
Check your house for hazards,  
Check your house for hazards,  
You'll be smart. You'll be smart.  
Hunt for hazards, hunt for hazards,  
Clean them out, clean them out.  
Help protect your family,  
Help protect your family,  
Have no doubt, have no doubt.

**Bike Song****Bicycle Built for Two**

*Baltimore Area Council*

Daisy, Daisy, give me your answer, do,  
I'm half crazy, all for the love of you,  
It won't be a stylish marriage,  
I can't afford a carriage,  
But you'll look sweet, on the seat,  
Of a bicycle built for two~,

**STUNTS AND APPLAUSES****APPLAUSES & CHEERS**

*Alice, Golden Empire Council*

**Who's Responsible Applause**

Divide audience into four groups and give each one a phrase to say when you point to them, as follows:

Group #1 - "Who?"

Group #2 - "Me" (point to self)

Group #3 - "You"

Group #4 - "Responsible"

Applause leader should point from group to group in different order several times, then shout loudly, "Who's Responsible?" and point to both "Me" and "You" groups.

**You Did It Applause** - Everyone shouts "You DID It!!" three times, getting louder each time. (Applause leader can indicate getting louder)

**Webster's Got It Applause** - Everyone says "What's That Mean?" Then make the motion of taking down Webster's Dictionary from a shelf, open the book and search down the pages, then point and yell - "Got It!"

**Smoke Alarm Applause** - Everyone makes a loud "Beep-Beep" sound three times, then say "Good Job - It's In Working Order!"

**Spell It Out Applause** - Leader shouts out each letter, then audience repeats:

Give me an R...

Give me an E...

Give me an S...

Give me a P...

Give me an O, N, S and I...

Give me a B,

Give me an I,

Give me an L

And another I...

Give me a T

And a final Y....

What does it spell? "

Everyone shouts "Responsibility - that's Me

**RUN-ONS****"It's Not My Fault - It's the Job!"**

*Alice, Golden Empire Council*

*(Use this all during the Pack Meeting - one or two at a time - Make sure to emphasize words and ham up your performance!)*

- ✓ My first job was working in an orange juice factory, but I got CANNED...I just couldn't CONCENTRATE.
- ✓ I managed to get a good job working for a pool maintenance company, but the work was just too DRAINING.
- ✓ Then I worked in the woods as a lumberjack, but I just couldn't HACK it, so they gave me the AXE.

- ✓ After that I worked in a blanket factory, but it FOLDED.
- ✓ Next was a job in a shoe factory; I tried but I just didn't FIT in.
- ✓ After many years of trying to find steady work I finally got a job as a historian until I realized there was no FUTURE in it.
- ✓ My best job was being a musician, but eventually I found I wasn't NOTEworthy.
- ✓ I became a professional fisherman, but discovered that I couldn't live on my NET income.
- ✓ My last job was working at Starbucks, but I quit because it was always the same old GRIND.
- ✓ SO I RETIRED AND FOUND I'M PERFECT FOR THE JOB!

### JOKES & RIDDLES

*Alice, Golden Empire Council*

- Q: Why did the lazy man want a job in a bakery?  
A: So he could loaf around!

#### Vacation's Over

*Alice, Golden Empire Council*

Summer vacation was over and Little Johnny returned back to school. Only two days later his teacher phoned his mother to tell her that he was misbehaving. "Wait a minute," she said. "I had Johnny with me for three months and I never called you once when he misbehaved!"

#### Just Sitting In Class

*Alice, Golden Empire Council*

**Teacher:** "Isaac Newton was sitting under a tree when an apple fell on his head and he discovered gravity. Isn't that wonderful?"

**Student:** "Yes sir, if he had been sitting in class looking at books like us, he wouldn't have discovered anything."

#### It's Not My Fault!

*Alice, Golden Empire Council*

**Teacher:** Why are you late?

**Boy:** Because of a sign down the road.

**Teacher:** What does a sign have to do with your being late?

**Boy:** The sign said, "School Ahead, Go Slow!"

#### Responsibility & Perception

*Alice, Golden Empire Council*

While on a car trip, a family stopped at a roadside restaurant for lunch. Only after traveling several miles did the son realize he had left behind a treasured baseball cap. By then, they had to travel quite a distance before they could find a place to turn around.

All the way back, Dad fussed and fumed about the delay, telling his son he should be more responsible about his belongings.

When they finally arrived, as the boy got out of the car to retrieve his forgotten treasure, his Dad said, "While you're in there, you may as well get my sunglasses, too."

#### Responsibility & Consequence

*Alice, Golden Empire Council*

Little Johnny wasn't getting good marks in school. One day he surprised the teacher with an announcement. He tapped her on the shoulder and said, "I don't want to scare you, but my daddy says if I don't start getting better grades, somebody is going to get a spanking!"

#### Keep track of things

*Alice, Golden Empire Council*

Little Johnny's kindergarten class was on a field trip to their local police station where they saw pictures, tacked to a bulletin board, of the 10 most wanted men. One of the youngsters pointed to a picture and asked if it really was the photo of a wanted person. "Yes," said the policeman. "The detectives want him very badly." So Little Johnny asked, "Why didn't you keep him when you took his picture?"

## SKITS

#### What's Wrong with this picture?

*Alice, Golden Empire Council*

*There is a Narrator, who could be the Leader, and two short skits with a main character and several other people. If you have fewer boys, you could use two dens, combine a couple of characters, or just do one of the skits instead of both. Whether you do one or more skits, you could end with the Responsibility Song.*

**Narrator:** The boys in Den \_\_\_\_ have been learning about Responsibility all month – we talked about what makes a person responsible, what happens if you are responsible, and what can happen if someone forgets to be responsible. Let's see a couple of examples – see if you think there's anything wrong here:

#### Responsibility Skit #1

This skit has 4 characters:  
a football coach, and 3 players.

**Player #1:** Where is Coach Myers? The game starts in five minutes.

**Player #2:** Here he comes now.

**Coach:** How's it going guys?

**Player #3:** We're fine, but we haven't warmed up and don't know the line-up.

**Coach:** You don't need to warm up. Line-up? Oh I forgot to work on that. Just use the same line-up as last game.

**Player #1:** What plays are we using tonight?

**Coach:** Plays? Oh, err, I didn't have time to decide that either. Where is my play book anyway? I think I left that at home.

**Player #2:** Coach, the game is just about to start. This is going to be a tough team to beat. Do you have any words of encouragement for us?

**Coach:** Sure, just go out there and beat.... What team do we play tonight?

**Player #3:** (Shaking his head) I think something is wrong here!

**Narrator:** So, what do You think? Is there something wrong here? Do players usually depend on their coach? How do you think you would feel if YOUR coach forgot? What about when YOU are responsible to do something - what would happen if YOU forgot to do what you said you would?

### Responsibility Skit #2

**Cub #1:** Where the Den Leader? He's five minutes late for our field trip.

**Den Leader:** (Slowly walking in) Hi guys. Sorry, I was late. I just got lost in conversation. Okay, let's turn to page 55 in your book.

**Cub #2:** Aren't we going bowling today?

**Cub #3:** Yeah, we all brought our permission slips. My Mom is here to go along!

**Den Leader:** Oh, I forgot. I didn't get around to making reservations. We'll do it next month.

**Cub #1:** Something is very wrong here.

**Narrator:** Do you think something is wrong here? How would you feel if you were one of these Cubs? There is something missing? What do you think it is? Here's a song with the answer:

*(Boys all start to sing Responsibility Song)*

### Jiminy Cricket or Lazy Lou? Skit"

*Alice, Golden Empire Council*

**Narrator:** Hi everyone – We're here to make see if our friend Johnny Cub Scout knows how to be responsible. Will he listen to the voice of his conscience – or Lazy Lou, and his bad choices?

**Cub #1:** What's that noise? *(ringing or buzzing sound)*

**Narrator:** Oh that's the Johnny Cub Scout's alarm clock! Come on Johnny – Time to Get Up!

**Cub #2:** Yeah, Johnny – You have to get up and brush your teeth! *(Shakes Johnny on the shoulder)*

**Cub #3:** Hey, Johnny, you have to finish your paper route before school. Get up!

**Johnny Cub Scout:** *(wakes up: yawns)* I am sooo tired. I don't want to go to school.

### Jaws theme plays.

**Lazy Lou:** *(Evil cackle; funny walk; sinister looking)* Hey, Johnny, you don't HAVE to go to school. Go back to sleep. You don't have to finish your paper-route. *(repeats) (cackles).*

### "Sparkle" music plays.

**Cub #1:** What's that sound? *(looking at "Jiminy Cricket" character)* "And who are you?"

**Conscience:** *(Tip-toeing; happy; giggling)* Remember Jiminy Cricket? Well, I'm Johnny Cub Scout's Jiminy Cricket – his conscience!

**Cub #5:** What are you so happy about?

**Conscience:** I'm happy because I know if Johnny Cub Scout listens to me he'll make the right choice and have a good day!

*(Turns to Johnny)* Come on Johnny, time to get up, brush your teeth and go do your paper route.

### Everyone freezes.

**Narrator:** Well everyone. What do you think Johnny Cub Scout should do? Should he go back to sleep?! *(wait for response).*

Are you sure?

Should he wake up, brush his teeth, and do his paper route? *(wait for response).* Let's see what happens...

**Johnny Cub Scout:** I don't want to go to school or do my paper-route. *(looks at Lazy Lou, who looks sneaky, then looks at his conscience )*

*Lazy Lou & "Jiminy Cricket" characters both argue and try to pull Johnny their way).*

**Johnny Cub Scout:** I really want to sleep – but people are going to be unhappy if I don't bring them their paper! No! I'm not going back to sleep. I am going to get up, brush my teeth, and finish my paper-route. Go away, Lazy Lou!

**All other Cubs & "Jiminy":** Great choice, Johnny! We knew you could do it. Have a great day!

**Narrator:** Well, it looks like Johnny Cub Scout made the right choices! He showed that he knows how to be Responsible!

### G-I-V-E-S Goodwill

*Catalina Council*

This skit can be incorporated into many ceremonies. It is especially suitable for use during the time that your community is participating in a United Way campaign or an independent finance drive for Scouting's sustaining membership enrollment (SME).

PERSONNEL: Five Cub Scouts.

EQUIPMENT: Five large cards, each printed with a letter of the word G-I-V-E-S.

ARRANGEMENT: Each of the five Cub Scouts holds his card with the blank side to the audience. One at a time the boys step forward, turn their card so the audience may see the letter, and recite the phrases given below. When all have recited, they will be lined up left to right, their letters spelling out the word GIVES.

**Cub #1:** G-Stands for Giving. It's always good to give.

**Cub #2:** I-Stands for Intentions. May mine be always right.

**Cub #3:** V-Stands for Valiant A trait of great might.

**Cub #4:** E-Stands for Eager From beginning to end.

**Cub #5:** S-Stands for Sharing. This makes me a friend.

## CLOSING CEREMONIES

### Who's Responsible?

Alice, Golden Empire Council

Have each Cub hold a sign with an appropriate picture (samples given) on front (audience side) and his words on back in LARGE print.

**Narrator:** Without the courageous and responsible actions of many people, our country's Flag would have no meaning.



**Cub #1:** Our Founding Fathers risked their lives and property to declare independence from the strongest country in the world at that time.



**Cub #2:** Citizen soldiers left homes and families and served, often without pay for months, to fight for independence.



**Cub #3:** Today men and women leave home and families to take responsibility for protecting us and our freedom.



**Cub #4:** Every person who votes is taking responsibility for making their own choices as citizens.



**Cub #5:** Scouts take responsibility for taking care of the earth and doing service in the community.

**Narrator:** And each of us can take responsibility for being good citizens each time we honor the symbol of our Country – the Flag. (*Continue with closing Flag Ceremony*)

### Cubmaster's Minutes

#### The Goose Story

Baloo's Archives

Most of us have seen Canadian Geese heading north for spring. They fly in a V formation. When you see geese flying along in a V formation, you might consider that science has discovered why they fly that way:

As each bird flaps its wings, it creates an uplift for the bird immediately following. By flying in V formation, the whole flock creates at least 71% greater flying range than if each bird flew on its own. Each goose in each position in the V has a responsibility to help all the others.

People who share a common direction and sense of community can get where they are going faster and easier because they are traveling on the trust of one another.

When a goose falls out of formation it suddenly feels the drag and resistance of trying to go it alone and quickly gets back into formation to take advantage of the lifting power from the bird in front. It's like riding the draft in NASCAR. If we had as much sense as a goose we would stay in formation with those who are headed in the same direction that we are.

When the head goose gets tired, it rotates back and another goose flies point. We need you all to cooperate and work together. It is your responsibility to help the others in your den and pack. It makes sense to take turns doing demanding jobs whether it's with people or with geese flying north. No matter if you're the head goose or one in formation, we're all going for True North\* together.

#### Responsibility I

Troop 310, Clark, NJ

I'd like to read you some notable quotes:

"Responsibility: A detachable burden easily shifted to the shoulders of God, Fate, Fortune, Luck or one's neighbor."

"I must do something" always solves more problems than "Something must be done."

"You must take personal responsibility. You cannot change the circumstances, the seasons, or the wind, but you can change yourself. That is something you have charge of."

"Few things help an individual more than to place responsibility upon him, and to let him know that you trust him."

"If you want children to keep their feet on the ground, put some responsibility on their shoulders."

"The best years of your life are the ones in which you decide your problems are your own. You do not blame them on your mother, the ecology, or the president."

You realize that you control your own destiny."

In short, you need to be responsible individuals. You need to accept the personal responsibility that goes with being a part of the groups and activities you have chosen to be a part of. They are your responsibilities, and you must make every



effort to do your part, and not to place the burden of responsibility on someone else's shoulders.

### Responsibility II

*Troop 310, Clark, NJ*

*(Required: 1 dollar bill for each patrol leader)*

Can someone tell me who Bob Mazzuca is?

He is the Chief Scout Executive of the Boy Scouts of America. The head honcho, top dog, big cheese. He has the responsibility of setting direction for the future of the BSA and that is a huge task.

In an interview, Mr. Mazzuca was asked: What is the most important thing about leadership today that is not being taught to the nation's youth?

His answer: Personal responsibility. Taking responsibility for your actions is a hallmark of a good leader.

Personal Responsibility – that means understanding that where you are and what you are doing is up to you. You can't blame it on your folks, or society, or even the scoutmaster. You are responsible for reaching your goals.

Scouts in leadership positions are expected to meet a set of goals. By meeting those goals, the scout demonstrates responsibility and leadership and can advance in rank. When the scout chooses to not meet the goals, the scout's advancement is delayed and he gets to try again.

What you need to remember about leaders is that they have to make decisions, take chances, and accept the results. You've probably heard "The Buck Stops Here". That means that I am taking full responsibility for my actions. I am not passing the buck, or the blame, on to anyone else. That quote was from President Harry S. Truman.

For each of our key leaders (Cubmaster, Assistant CMs, Committee Chairs, DLs, WLs - your choice), I have a dollar bill with "The Buck Stops Here" written on it. I would like them to take it and keep it in their Scout Leader's Handbook (or your Scout folder) where you can see it often to remind you of your responsibility. It is to remind you to take responsibility, not pass the buck. A good leader, and a good scout, takes responsibility for his actions.

## CORE VALUE RELATED STUFF

### Teachers & Den Leaders Weigh in on Responsibility

*Alice, Golden Empire Council*

Being Responsible is a necessary trait if a teacher is to have a classroom that works – and like teachers, Den Leaders also work to help their students become responsible in many ways. Check out these activities suggested by teachers and creative Den Leaders:

- **Interpersonal Responsibility:** One teacher talks about classroom rules, letting her students help decide on rules and consequences. As a Den Leader, you can do the same – just make sure you have only a few basic rules that everyone understands. Post your list at the front of the den room each meeting – if a rule is being broken, just point to the list and ask "What's the Rule?" No need to get into a discussion with an individual boy,

since the den all worked on the rules and consequences together. (You might even have to check the boy's ideas when they decide on consequences – they are often far too severe)



- **Leg by Leg Responsibility Spider:** Here's another fun idea to get boys thinking about taking responsibility for their part - organize boys into a small-group assembly line. Then challenge them to make a product using materials you provide. This could be any kind of project, but one teacher has the group make a spider-- use two sizes of Styrofoam ball halves, pipe cleaners, and small round-topped map pins. Each boy has the responsibility of adding a particular part of the spider. Once groups have created their products, a designated, impartial "inspector" determines if the groups' products pass muster.
- (A group of kids in my church just used this same idea in putting together Humanitarian Aid school kits – with each child responsible for putting the right items in one school bag at a time, or being responsible for making sure that the right number of pencils or notebooks was put in each bag. When we finished, we had one ruler left over, so the kids had to take responsibility to find the bag that was missing a ruler – **and there's the lesson – sometimes we adults just "fix" things ourselves – instead of letting the boys be responsible! Alice**)
- **Behavior Journals:** Teachers often have students write in their own personal journals about their week's behavior and how they handled problems that came up. At the end of the week, they take their journals home to share with parents. As a Den Leader, you can help boys with behavior issues to take personal responsibility by having them write down what happened, and how they think the problem could be solved. You can also give out "Positive" reports to take home to parents. Baden-Powell said "A pat on the back is a stronger stimulus than a prick with a pin. Expect a great deal of your boys and you will generally get it." Set a goal to say at least one good thing about each boy at every den meeting. But don't give undeserved compliments – boys know when the praise is genuine! Remember, **"It's better to build boys than repair men."**



- **A Taste of Responsibility:** At the beginning of the meeting, "post" a length of SHOESTRING LICORICE for each boy at the front of the room – give instructions that they won't receive the licorice till the meeting ends, and that each boy will get whatever is left of his piece at that time. Every time you need to discipline the boy, cut off two inches (or whatever amount you decide). **Don't say anything, just walk over and cut off the "consequence."** If the boy wants to know why, just remind everyone that you explained the rules at the beginning – then go on with your activity.







- Responsible Service: Have each boy make a coupon book to give to his parents or teacher, or even to use at scouts. The boys should include coupons good for the adult to “redeem” in exchange for service from the boy. Each boy can include things such as “sorting the recycling” or “sweep the back porch” or “pass out materials.” Then have the boys turn in their completed coupon books when they have taken responsibility to do each promised task. A word of warning: these tasks should not include regular chores or assignments – they should be for extra things each boy can do.
- “Caught Being Good Coins:” One Den Leader I worked with uses special plastic “coins” – when a boy is “caught” doing something good – helping without being asked, cleaning up after an activity, helping another boy with a project or craft. Boys cannot ask for a job to earn a coin – they are rewarded for choosing to be helpful and take responsibility for themselves and their materials, books, candy wrappers, whatever. Coins are redeemed for simple toys, stickers, party favor type stuff, sometimes a patch.
- Clock Watch: Some teachers have students post paper clocks next to their real clock at home, to remind themselves when to do things. This is especially helpful for kids who tend to be tardy. Make each of the boys responsible for being on time to den meetings. You could also make one boy each meeting responsible for being the “Time Keeper.” Give him a schedule of your agenda and a watch. He is responsible for telling you when you need to move on to the next activity



Make a Smoke Alarm Calendar:

Using either calendars from the Dollar Store, or a calendar printed out from online, each boy can make a special Smoke Alarm Calendar for his family. Fire Department Officials suggest that you change the batteries on your smoke alarm twice a year, so have each boy mark his calendar for June 21<sup>st</sup> and December 21<sup>st</sup> – or another date that will be easy for him to remember. The calendar should be posted where the scout can be reminded to be responsible to make sure his family smoke alarm batteries are checked.

- Assignment Organizer: Teachers often have their students record their assignments in a special notebook, so they can check off what they do in class – whatever isn’t done becomes homework, which they take home. Both parents and students initial the list before it returns to school. As a Den Leader, have a process for “homework” – things that must be done at home. Make sure there is some kind of check-off for the boy to do – you could have a chart to post at the Den Meeting, so that boys can initial or put a sticker when they have completed the homework. Some dens have an email system – so parents could be reminded. But it’s important to have some way for each boy to keep and mark off his OWN record as well, especially with assignments that require more than one time. Here’s an example for Wolf Ach. #3:

	Sun	Mon	Tues	Wed	Thu	Fri	Sat
Bathe or Shower 							
Wash hands  Before meals and after using the toilet							
 Brush before bed & after breakfast							
 Drink Lots of Water							
 Play outdoors							
Get enough sleep 							

- Money Matters: To help students understand budgets, teachers often use play money, provide each student with a list of necessary expenses, and have them figure out how to use their “money.” As Den Leaders, we can work on the scout or religious award requirements that involve learning how to use money.  
***We can also let the boys take an active role in planning the expenses for a den or pack activity, so they get a realistic view of how much things cost.*** Every scout should have an opportunity to earn at least part of the money for Day Camp – encourage parents to offer chores for hire, or use a den or pack project, such as a car wash or popcorn sales – where the boy himself can be responsible for part of the cost.

## DEN MEETING REVUE

If you have questions on the new delivery method, any of the new books, roundtables, or anything else - and wish to contact National, here is the contact information for people who can help -

E-mail -

[program.content@scouting.org](mailto:program.content@scouting.org) or  
[bob.scott@scouting.org](mailto:bob.scott@scouting.org)

The last issue of "*The Commissioner*" had this entry - "For assistance with the new Cub Scout program, including roundtables, contact Don Shepard, Youth Development Team leader, at [donald.shepard@scouting.org](mailto:donald.shepard@scouting.org) or call 972-580-2547."

*Wendy jumped right on the idea of this item. So here is the second attempt at a few suggestions each month for two den meetings per rank. Comments welcome CD*

### CONNECTING CORE VALUES WITH OUTDOOR ACTIVITIES

*Catalina Council*

- ★ Pair up with a buddy and be **responsible** for him throughout the hike. Stay on the trail. Leave no trace.
- ★ Each boy brings a specific nature time to the meeting demonstrating he is **responsible** to remember his assignment. Also, each boy is **responsible** in bringing items that are allowed and not disturbing any nature preserve or ecology site.
- ★ Mow the grass for elderly neighbor for a specified duration. Make a duty roster. Each Scout is **responsible** to do his part.
- ★ Each boy is **responsible** to bring certain piece of equipment to play a game (bat, ball, glove for baseball).
- ★ Do a den ceremony where each boy is **responsible** to act or say his part. Adults model **responsibility** by having advancement.
- ★ Boys could help set up and clean up campfire area. They are **responsible** to make sure the fire is completely out.
- ★ Visit a local bank or credit union and talk about how these institutions are **responsible** for safeguarding other people's money.
- ★ Have boys help to plan one of the overnighter activities. Be sure to evaluate afterwards to discuss how success is related to **responsible** behavior.

\*\*\*\*\*

*Wendy Chief Seattle Council*

#### Den Meetings

#### Seasonal Ideas -

- © Halloween Ideas: <http://familyfun.go.com/halloween/>
- © Fire Safety Activities for children, US Fire Administration - Kids' Page,

<http://www.usfa.dhs.gov/kids/parents-teachers/resources.shtm>

#### Field Trip Planning:

- Tour Permit Form:  
<http://www.scouting.org/filestore/pdf/34426.pdf>
- Activity Consent Form:  
<http://www.scouting.org/filestore/pdf/19-673.pdf>

#### Games to play while traveling or on field trips:

- **The "Quiet Games"** section of [How To Book](#) p. 3 - 36 to 38 has several ideas.
- **I Spy**  
**I spy** is a [guessing game](#) usually played in families with young children, partly to assist in both observation and in alphabet familiarity. It is often played as a [car game](#).

One person starts by choosing an object (a *cow*, for example) and says "I spy with my little eye, something beginning with C" or simply "I spy something beginning with C." The other players look around and suggest things it might be: "Crow" (no), "Car" (no), "Cloud" (no), "Cow" - yes. The person who guesses correctly often gets to choose the next object.

Often the game is played without the accumulation of points, and winning a round simply results in the initiation of further play.

When played in a car, the group playing may need to decide beforehand what to do about items that are no longer visible (the field with the cows is a mile back - usually permitted but the person choosing the object has to say "I can't see it any more" and "I can see it now"). Sometimes items within the car are excluded.

A slightly more challenging version uses phrases - "I spy with my little eye something beginning with B A W C" for "Black and white cow". Another variation of this game is to play using colors, such as 'I spy with my little eye something that is green'.

A further variation to the game is titled 'I hear with my little ear'. It functions, as the title suggests, with sounds instead of sights.

- **20 Questions.**

*Twenty Questions* is a [spoken parlor game](#) (or [car game](#)) which encourages [deductive reasoning](#) and [creativity](#). It originated in the [USA](#) and escalated in popularity during the late 1940s when it became the format for a successful weekly radio quiz program.

In the traditional game, one player is chosen to be the *answerer*. That person chooses a subject but does not reveal this to the others. All other players are *questioners*. They each take turns asking a question which can be answered with a simple "Yes" or "No". In variants of the game (see below), multiple state answers may be included such as the answer "Maybe". The answerer answers each question in turn. Sample questions could be: "[Is it bigger than a breadbox?](#)" or "Can I put it in my mouth?" Lying is not allowed, as it would ruin the game. If a questioner guesses the correct answer, that questioner wins and becomes the *answerer* for the next round. If 20 questions are asked without a

correct guess, then the answerer has stumped the players and gets to be the answerer for another round.

#### Variations

The most popular variant is called "Animal, Vegetable, Mineral". This is taken from the old, possibly [Renaissance](#), idea that all [life](#) was [animal](#) or [plant](#) (vegetable), and that non-living (which is to say, never-living) matter must be mineral. In this version, the *answerer* tells the *questioners* at the start of the game whether the subject is an [animal](#), [vegetable](#) or [mineral](#). These categories can produce odd technicalities, such as a wooden table being classified as a vegetable (since wood comes from trees).

Other versions specify that the item to be guessed should be in a given category, such as [actions](#), [occupations](#), [famous people](#), etc. A version of Twenty Questions called [Yes and No](#) is played as a [parlor game](#) by characters of [Charles Dickens' A Christmas Carol](#). A children's version is played with the categories, "Animal, Vegetable, Mineral, Candy

#### Managing Boy Behavior:

- Code of Conduct: [How To Book](#) p. 1—13-15.
- Den Doodles: [How To Book](#) p. 1—3-4.
- For more Den Discipline ideas go to <http://usscouts.org/usscouts/bbugle/bb0911.pdf> p. 5-7.  
<http://usscouts.org/usscouts/bbugle/bb0809.pdf> p. 3-5.

### TIGERS

Ach. #3 Keeping Myself Healthy & Safe,  
E28 Smoke Detectors;

#### Den Meeting #3:

- Ach. #3Fb What to do if lost;
- Ach. #3D Food Pyramid;
- Ach. #3Fa Plan a family fire drill;
- E28 Check batteries in smoke detector;
- Ach. #3D Health & Fitness Character Connection;
- Ach. #3G Rules for sport or game.

#### Den Meeting #4: Field Trip:

- Ach. #3G Watch a game or sporting event.

*Tigers might also want to do El. #27 Emergency!*

#### Food-related Games & Gathering Activities:

*Check out Gathering Activities, Den and Pack Activities, Games, and Songs for Food Related things to use while working on the Food Related Achievements and Electives.*

This web site has links to several publications (Including Baloo's Bugle) with ideas from Food related themes - For "Cub Cafe", April 2007,

<http://www.scoutingthenet.com/Training/Roundtable/Handouts/07/03/>

For "Cub Grub", March 2000

<http://www.scoutingthenet.com/Training/Roundtable/Handouts/00/02/>

For "Holiday Food Fare", December 2004

<http://www.scoutingthenet.com/Training/Roundtable/Handouts/04/11/>

#### Fire Safety Ideas

Fire Safety Activities for children, US Fire Administration - Kids' Page, <http://www.usfa.dhs.gov/kids/parents-teachers/resources.shtml>

#### Fire-related Games & Gathering Activities:

*Check out Gathering Activities, Den and Pack Activities, Games, and Songs for Fire Related things to use.*

#### For more Fire Fighter Games & Crafts:

[http://www.amazingmoms.com/html/party\\_firefighterparty.htm](http://www.amazingmoms.com/html/party_firefighterparty.htm)

<http://familyfun.go.com/parties/birthday/feature/famf58birthday/famf58birthday2.html>

Fire Fighter Hat:

[http://www.makingfriends.com/firemans\\_hat.htm](http://www.makingfriends.com/firemans_hat.htm)

### WOLVES

Ach. #2 Your Flag,  
Ach. #3 Keep Your Body Healthy,  
E20 Sports, Bowling Belt Loop.

#### Den Meeting #3:

- Ach. #2b or #2f Flag ceremony;
- Ach. #2a Pledge of Allegiance;
- Ach. #2c How to display, respect, and care for the flag;
- Ach. #2d State Flag;
- Ach. #2e Learn how to raise flag for outdoor flag ceremony;
- Ach. #2g Fold the flag.
- Ach. #3 Health Chart.
- E20h sprint start;
- E20i standing long jump;
- E20 j Flag football, or E20k soccer, or E20l baseball or softball; or E20m basketball.
- Bowling Belt Loop #1 Bowling rules.

#### Den Meeting #4:

- Ach. #3a Verify health chart;
- Ach. #3b Preventing colds;
- Ach. #3c Treating cuts.
- E20g Bowling

#### NOTE:

The Wolves may want to do their litter walk (Ach. #7d) in the next couple of months. If you follow the schedule in the new Cub Scout Den & Pack Meeting Resource Guide, the boys will be collecting litter in December.

#### Sports Ideas

#### Sports-related Games & Gathering Activities:

*Check out Gathering Activities, Den and Pack Activities, Games, and Songs for Sports Related things to use while working on the Sports Related Achievements and Electives.*

Or for more ideas -

<http://usscouts.org/usscouts/bbugle/bb0207.pdf>

#### Table Top Sports:

- ♣ Football: <http://familyfun.go.com/playtime/play-tabletop-football-707287/>
- ♣ Soccer: <http://familyfun.go.com/playtime/tabletop-games/tabletop-soccer-844529/>

<http://familyfun.go.com/playtime/tabletop-games/paper-ball-soccer-817885/>

- ♣ Basketball: <http://familyfun.go.com/playtime/tabletop-games/ping-pong-basketball-817459/>
- ♣ Golf: <http://familyfun.go.com/playtime/tabletop-games/flip-golf-817439/>
- ♣ Shuffleboard:  
<http://familyfun.go.com/playtime/tabletop-games/shuffle-caps-817886/>

#### For more ideas see:

- ★ 2008 Olympic theme "Go for the Gold":  
<http://www.scoutingthenet.com/Training/Roundtable/Handouts/08/05/>
- ★ 2002 "Sports Extravaganza" theme:  
<http://www.scoutingthenet.com/Training/Roundtable/Handouts/02/07/>
- ★ 2009 "Be a Sport" theme:  
<http://www.scoutingthenet.com/Training/Roundtable/Handouts/09/06/>
- ★ 2010 "Hoop-de-Doo" theme:  
<http://www.scoutingthenet.com/Training/Roundtable/Handouts/10/05/>
- ★ 2005 "Play Ball" theme:  
<http://www.scoutingthenet.com/Training/Roundtable/Handouts/05/06/>

#### Your Flag Ideas

Ach. #2d Your State Flag, and state symbols:

Go to any of these sites to learn all about your state flag and other symbols -

- ★ <http://www.netstate.com>
- ★ <http://www.enchantedlearning.com/usa/flags/>
- ★ <http://www.50states.com/>

In Baloo's Bugle for "My Home State," CD listed a kid's site for each state. Here it is. If your state's site has changed, drop dave anote s he can update the list.

### State Websites for Kids

#### Alabama Kids Page

<http://www.alabama.gov/facts/kidspages.html>

#### Alaska Stuff for Kids

<http://www.state.ak.us/kids/>

#### American Samoa

<http://academickids.com/world/geos/aq.html>

#### Arizona - About Arizona for Kids

<http://www.lib.az.us/links/kidsAZ.cfm>

#### Arkansas Kids

<http://www.arkansaskids.com/>

#### California Kid's Korner

[http://www.dre.ca.gov/kids\\_sub.htm](http://www.dre.ca.gov/kids_sub.htm)

#### Colorado Kids and Students Page

<http://www.state.co.us/kids/index.html>

#### Connecticut Connect Kids

<http://www.kids.state.ct.us/>

#### Delaware Kids Page

<http://www.state.de.us/gic/kidspage/kidspage.htm>

#### District of Columbia Kids' Capital

<http://kids.dc.gov/>

#### Florida Kids' Corner

<http://taxonomy.myflorida.com/Taxonomy/Visitor/Kids%20Corner>

#### Florida Kids

<http://dhr.dos.state.fl.us/kids/index.html>

#### Georgia

<http://www.atozkidsstuff.com/georgia.html>

#### Guam

<http://www.guam-online.com/people/people.htm>

#### Hawaii

<http://www.atozkidsstuff.com/hawaii.html>

#### Idaho Kid Book

<http://www2.state.id.us/gov/fyi/kidbook/index.htm>

#### Idaho Just for Kids

<http://www.accessidaho.org/education/kids.html>

#### Illinois Kid Zone

<http://www.state.il.us/kids/>

#### Indiana Little Hoosiers' Kid Page

<http://www.in.gov/sic/kids/>

#### Iowa Kids Too

<http://www.state.ia.us/main/addressbooks/ADkids/index.html>

#### Kansas Lawrence Recycling Page

<http://www.lawrencekidsrecycle.org/>

#### Kansas

<http://www.accesskansas.org/facts-history/index.html>

#### Kentucky Kids' Pages

[http://kentucky.gov/Portal/Category/fac\\_kids](http://kentucky.gov/Portal/Category/fac_kids)

#### Louisiana Just for Students

<http://www.louisiana.gov/wps/portal/.cmd/cs/.ce/155/.s/1118/s.155/1088/me/1117/>

#### Maine Kids' Page

<http://www.state.me.us/sos/kids/>

#### Maryland

<http://www.mdkidspage.org/>

#### Massachusetts Kids' Zone

<http://www.state.ma.us/sec/cis/ciskid/kididx.htm>

#### Michigan MI Kids

<http://www.michigan.gov/mikids>

#### Michigan Kidz Korner

<http://www.mda.state.mi.us/kids/index.html>

#### Minnesota Student Page

<http://www.sos.state.mn.us/student/netscape4.html>

#### Mississippi Treasure Chest of Educational Resources

<http://www.ms.gov/frameSet.jsp?URL=http%3A%2F%2Fwww.mde.k12.ms.us%2Fms.htm>

#### Missouri Kids Page

<http://www.gov.state.mo.us/kids/>

#### Montana is for Kids

<http://montanakids.com/>

#### Nebraska Online

<http://www.nol.org/html/293/index.phtml>

#### Nebraska's Legislature's Website for Kids

<http://www.unicam.state.ne.us/kids/index.htm>

#### Nevada

<http://firstlady.state.nv.us/Trivia.htm>

#### New Hampshire Senate Page for Kids

<http://www.gencourt.state.nh.us/senate/misc/kids.html>

#### New Jersey Hang Out NJ

[http://www.state.nj.us/hangout\\_nj/](http://www.state.nj.us/hangout_nj/)

**New Mexico**

<http://www.state.nm.us/category/aboutnm/fastfacts.html>

**New York for Kids**

<http://www.iloveny.com/kids/index.asp>

**North Carolina Kids Page**

<http://www.secretary.state.nc.us/kidspg/>

**North Dakota Kid Zone**

<http://discovernd.com/kidzone/>

**Northern Mariana Islands**

<http://academickids.com/world/geos/cq.html>

**Ohio OH Kids**

<http://oplin.lib.oh.us/products/oks/>

**Oklahoma**

<http://www.youroklahoma.com/?c=8>

**Oregon Blue Book**

<http://bluebook.state.or.us/kids/kids.htm>

**Pennsylvania Kids Pages**

<http://www.state.pa.us/papower/taxonomy/taxonomy.asp?DLN=29872>

**Puerto Rico**

<http://www.elboricua.com/BoricuaKids.html>

**Rhode Island**

<http://www.ri.gov/browse.php?choice=mpage&mcat=8>

**South Carolina**

<http://www.50states.com/scarolin.htm>

**South Dakota**

<http://www.state.sd.us/about.htm>

**Tennessee Kids Pages**

<http://www.tennesseeanytime.org/residents/children.html>

**Texas Senate Kids**

<http://www.senate.state.tx.us/kids/>

**Utah Kids Page**

<http://www.utah.gov/learning/kidspage.html>

**Vermont Kid's Page**

[http://www.sec.state.vt.us/Kids/kids\\_index.htm](http://www.sec.state.vt.us/Kids/kids_index.htm)

**Virgin Islands**

<http://www.countryreports.org/virginislands.htm>

**Virginia Kids Commonwealth**

<http://www.kidscommonwealth.virginia.gov/home/>

**Washington Just for Kids**

<http://access.wa.gov/kids/>

**West Virginia Kids' Page**

<http://www.legis.state.wv.us/kids/kids.html>

**Wisconsin Agency Pages for Kids**

[http://www.wisconsin.gov/state/core/kids\\_page.html](http://www.wisconsin.gov/state/core/kids_page.html)

**Wyoming Kid's Page**

<http://www.state.wy.us/kids.asp>

**Flag-related Games & Gathering Activities:**

*Check out Gathering Activities, Den and Pack Activities, Games, and Songs for Flag Related things to use while working on the Flag Related Achievements and Electives.*

**Patriotic Activities:**

<http://familyfun.go.com/4th-of-july/>

<http://www.makingfriends.com/Patriotic.htm>

For more ideas for "Your Flag" see

The 2001 & 2009 theme "American ABCs":

<http://www.scoutingthenet.com/Training/Roundtable/Handouts/09/01/>

<http://www.scoutingthenet.com/Training/Roundtable/Handouts/01/06/>

The 2006 theme "Red, White, & Baloo":

<http://www.scoutingthenet.com/Training/Roundtable/Handouts/06/0>

The 2010 theme "Celebrate Freedom":

<http://www.scoutingthenet.com/Training/Roundtable/Handouts/10/06/>

The 2000 theme "Sea to Shining Sea":

<http://www.scoutingthenet.com/Training/Roundtable/Handouts/00/06/>

**BEARS**

Ach. #14 Ride Right,

Ach. #7 Law Enforcement

**Meeting #3:**

Bike shop field trip or guest speaker:

Ach. #14a Bike safety rules;

Ach. #14b Learn to ride a bike;

Ach. #14c Keep your bike in good shape;

Ach. #14c Bicycle lock.

**Meeting #4:**

Ach. #7 Police Station field trip:

Ach. #7b Visit police station, or talk to law enforcement officer about crime prevention;

Ach. #7c Help with home crime prevention;

Ach. #7d Know where to get help in your neighborhood;

Ach. #7e Emergency phone numbers;

Ach. #7f Know what you can do to help law enforcement;

Ach. #7a Practice one way police gather evidence.

**Note:**

To coordinate better with the pack night activities for Fire Safety, Bears might want to do Ach. #11, "Be Ready" this month. Be sure that if you switch den meeting plans, boys are still able to get their rank advancement by February (if your pack likes to present rank patches at the Blue & Gold Banquet).

The pack night activity for June is a bike rodeo, so Ach. #14, "Ride Right" would coordinate nicely with that month's Pack activities.

**Biking Ideas**

Bicycling Belt Loop & Pin:

<http://usscouts.org/advance/cubscout/sports/bicycling.asp>

**Bike-related Games & Gathering Activities:**

*Check out Gathering Activities, Den and Pack Activities, Games, and Songs for Bike Related things to use while working on the Bike Related Achievements and Electives.*

**Law Enforcement Ideas****Law Enforcement-related Games & Gathering Activities:**

*Check out Gathering Activities, Den and Pack Activities, Games, and Songs for Law Enforcement Related things to*

use while working on the Law Enforcement Related Achievements and Electives.

**More Ideas -**

2002 Baloo's Bugle "Kids Against Crime" p. 3-9.

<http://usscouts.org/usscouts/bbugle/bb0210.pdf>

2002 Tatanka District "Kids Against Crime" p. 4-5.

<http://pages.prodigy.net/lisabackusmith/Handouts/Kids%20Against%20Crime.PDF>

**Webelos are at the end of Baloo in their own special section!!!**

**PACK AND DEN ACTIVITIES**

**Den & Pack Activity Ideas**

*Alice, Golden Empire Council*

- ℞ **Invite a military service member or other qualified person to come and explain the responsibility for proper flag etiquette**  
*(In Sacramento, we have a wonderful event called "The Eternal Flame Flag Retirement & Advancement Weekend" where scouts of all ages, along with the public, can learn how to show respect for the flag. Flags that are dirty, faded or torn are collected and burned with the proper ceremony and respect, and people learn all about proper etiquette. The event also benefits "Soldier's Angels" which helps both military members and their families. Your den or pack could do this on a smaller scale, and include information about the history of the flag and the cost of freedom. Make sure the boys understand that they have responsibility for how they behave at a flag ceremony or when doing the Pledge of Allegiance – Let me know if you want ideas! Alice)*
- ℞ **Help boys take responsibility for good sportsmanship and good manners** - Talk with them about how they can show good manners in different circumstances, especially at sporting events; encourage boys and families to work on the Good Manners Belt Loop and Pin.
- ℞ **Use a dictionary or thesaurus to help understand the meaning of the Pledge of Allegiance** – talk about how scouts can be responsible for being good citizens
- ℞ **For more ideas and information, go to:**  
[www.firesafety.gov/kids/lesson/index.shtm](http://www.firesafety.gov/kids/lesson/index.shtm)
- ℞ **Take Responsibility for family fire safety - celebrate Fire Prevention Week (Oct. 3-9)** by making sure your pack family members know how to protect themselves from fire, and what to do in case of fire. See the idea for making smoke alarm calendars under Theme Related. Check with your local Fire Dept. or go to:  
[www.nfpa.org/displayContent.asp?categoryID=1439](http://www.nfpa.org/displayContent.asp?categoryID=1439)
- ℞ **Find the Fire Hazard** - Enlarge this picture to copy paper size and challenge each boy to find the fire hazards in this room.



- ℞ **Visit a local fire station** – then share brochures and what you learned with pack families at the pack meeting.
- ℞ **Work on the belt loop for Disability Awareness – Oct. is Disability Awareness month** – and each boy can learn how to respond to those with disabilities and how to dispel harmful attitudes.
- ℞ **Invite a guest who works with learning or physically challenged people to share something about their work** – Ask them to talk about how boys can help and what they should or should not do when working or playing with the “challenged.”
- ℞ **Visit a Pumpkin Patch** for a fun pack family activity. Check out the Harvest Games in this packet.
- ℞ **Encourage each boy, family and den to identify chores or jobs** for which they will take responsibility at home, at school or work, and in scouts. And a chart plus positive praise will go far!



- ℞ **Make Acorn Families**- Gather acorns or any other round or oval shaped things falling from your trees and create a family. We drew faces on ours with sharpies and then hot glued them to sticks we found. It was fun to see the kid's different faces and shapes of the acorn variety.
- ℞ **Utilize one or more of the ideas under Theme Related to help boys practice being responsible – “Teachers & Den Leaders Weight in On Responsibility.”** Lots of tools that will help the boys to be more responsible.
- ℞ **Celebrate Noah Webster’s birthday (Oct. 16, 1758)** – Boys can learn how to use the dictionary and thesaurus – and take responsibility for learning the meaning of words – and adding some new words to their vocabulary!
- ℞ **Choose a service project to be responsible for conservation, clean up or recycling.** Help the boys learn how to take care of the earth.



- ☞ **Earn the Year of Celebration patch** - It's all about taking responsibility! (or help the boys in your unit to earn it) You only have till the end of 2010! Go to : [www.scouting.org/100years/100years/ayeartofcelebration.aspx](http://www.scouting.org/100years/100years/ayeartofcelebration.aspx)



- ☞ **Introduce an "I Did It Jar" filled with penny candy that can only be opened if a boy remembers to wear his uniform and bring his book.** This really turned around a new den of boys who were very lax about wearing shirts and bringing books. And always praise those boys who remember!
- ☞ **Sign on for the Acorn Harvesting activity and be responsible for helping collect 2,000 acorns with a group** - to replant 50,000 oaks in the Sacramento area. Go to [www.sactree.com](http://www.sactree.com) In other areas all over the country, Arbor Day, Forestry or Tree Foundations have similar projects. Check with your local librarian for contact information.
- ☞ **Make posters about Fire Safety to post throughout the school.** You could also use the Smoke Alarm theme for this year.



- ☞ **Den Leaders can draw up a "contract" with the boys in their den to encourage everyone to take responsibility** – the Leader promises to plan ahead, be dependable, get trained, keep good records, keep in touch with families. Boys can promise to show up at meetings, wear their uniforms, bring their books, do their "homework," follow the den rules, and always Do their Best. (You could even include the parents – they could promise to get their boys to the meetings, bring their family to the pack meetings, encourage the boys to do homework, sew on patches, etc.)

### Behavior Journals

*Catalina Council*

To get boys to "own" their behavior, have them create and decorate journals in which they write about their week's behavior and how they handled problems that came up. Every week, review a handful of journals and write suggestions and encouraging comments. At the end of the month, boys take their journals home to share with their parents.

### Kindness Chain

*Catalina Council*



Near the front of your den meeting room place a basket with strips of paper and a pencil.

Each time boys do a good deed or perform an act of kindness, they write it on a strip of paper and tape the ends together to form the link of a chain.

Display the chain in your den meeting place first, and then at the Pack meeting as it grows through the year.

It provides such a great incentive that boys look for the opportunity to do something they can add to the chain.

### Let's Work Together

*Catalina Council*

With this fun activity, boys learn how to work with others and take responsibility for their part of a finished product. Organize the boys into a small-group assembly line. Then challenge them to make a product using materials you provide. Each boy has the responsibility of adding a particular part of the object. Once groups have created their products, a designated, impartial inspector determines if the groups' products pass muster.

**Example:** Styrofoam balls and pipe cleaners can make a spider.

### Clock Watch

*Catalina Council*

Ask boys to create paper clocks that show their scheduled times for getting-ready tasks, such as getting up, eating breakfast, dressing, and leaving for school. Encourage the boys to post these paper clocks next to their real clock at home, to remind themselves when to do things. This is especially helpful for boys who tend to be late.

### Car Safety

*Catalina Council*

To reinforce what we know about being safe in the car, have the boys make paper safety belts. Boys work together to measure their waists with string or a tape measure, adding a hand's width to the waist measurement for fastening. They cut a safety belt from colored paper and decorate it with car safety rules we've discussed. Boys wear their belts home with notes they've written to their parents about family car safety.



**SUGGESTED READING LIST –  
BOOKS THAT TEACH RESPONSIBILITY**

*Catalina Council*

"Few things help an individual more than to place responsibility upon him, and to let him know that you trust him." --Booker T. Washington

<u>Name of Book</u>	<u>Author</u>
All Alone	Claire Bishop
Tobi Tobias	Arthur Mitchell
Brave Irene	William Steig
The Case of The Stolen Bagels	Hila Colman
Fritz and the Mess Fairy	Rosemary Wells
Henry and the Paper Route	Beverly Cleary
Keep the Lights Burning Abbie	Peter Roop
Kid Power	Susan Pfeffer
My Buddy	Audry Osofsky
Nannabah's Friend	Mary Perrine
Pepe the Lamplighter	Elisa Bartone
The Plant Sitter	Gene Zione
Salt Boy	Mary Perrine
Best Mom in the World	Judy Delton
Bartholomew & the Oobleck	Dr. Seuss
Ida and the Wool Smugglers	Sue Anderson
Island Baby	Holly Keller

### Food Activities

#### Taco Tie Slide:

*Wendy, Chief Seattle Council*



#### Materials

4" Tan Craft Foam  
Red Craft Foam  
Yellow Craft Foam Green Paper  
PVC ring  
Hot Glue  
Scissors

#### Directions

- Cut 4" diameter circle from tan craft foam for taco shell.
- Cut thin strips of yellow craft foam for shredded cheese.
- Cut irregular shapes of red craft foam for tomato.
- Tear green paper into irregular shapes and wad up for lettuce.
- Fold taco shell in "U" shape.
- Using hot glue, attach cheese to bottom, then tomato, and finally lettuce on top.
- Make sure sides of taco are held in place, if not put on more hot glue.
- Hot glue a PVC ring to the back.

#### Bacon & Eggs Tie Slide:

*Wendy, Chief Seattle Council*



#### Materials

Bottle Caps

*Can't find classic bottle caps??*

*Go to [MakingFriends.com](http://MakingFriends.com) and you can buy them for less than 10 cents apiece. Unbelievable!! Of course, I never thought about buying crickets either until my daughter adopted an [Anole](#) CD*

Bacon & Eggs

Scissors

Paint & Brush

Tacky Glue

1/2 Mini Craft Stick

3/4" PVC pipe about 1/2" long (for loop)

Low Temp Hot Glue Gun and Glue Sticks

#### Instructions:

- Have the boys draw bacon & eggs (or pancakes or ... ) on piece paper that will fit in the cap.
- You can cheat here a little. Click this [link](#)
- Glue the picture to inside of bottle cap.
- Break mini craft stick in half.
- Paint black to look like a pot handle.
- Glue to back of bottle cap.
- Glue on a PVC pipe

### Fire Activities

#### Fire- Triangle Experiment

*Baltimore Area Council*



- Fire requires three things: air, fuel, and heat. Take away any one and the fire goes out. Demonstrate this with a wooden match and bottle.
- Have a Cub Scout (or a parent at the Den Meeting) strike a match (creating heat by friction). Let it burn a moment (using oxygen to burn the wood or fuel), and then drop it into the bottle and place his hand over the top. This cuts off the oxygen and the hatch goes out even though there is still plenty of fuel.
- Have a Cub Scout strike a match and dip it into a glass of water. The water cuts off the air and cools the fuel, extinguishing the fire even quicker
- Your boys may want to make a poster showing the fire triangle as illustrated.

### Fire Safety Posters Baltimore Area Council



Have boys create their own slogans and designs for posters. Use Poster Board and felt tip pens, crayons, or paint. Display at Pack Meeting.

## Sports Activities

### Ball Neckerchief Slides Wendy, Chief Seattle Council

#### 3-D Version

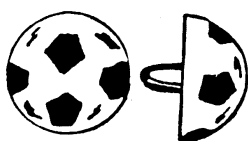

#### Materials:

Ping Pong ball (or half a Styrofoam ball)  
Plaster  
Pop top ring or small 1/2" pvc pipe ring  
Black acrylic paint

#### Directions

- ★ Cut a ping-pong ball in half.
- ★ Fill the half of ball with plaster and insert pop top or PVC ring for slide. (If using Styrofoam, glue ring on back)
- ★ Decorate with black paint.

*The same idea can be used to make a Basketball, etc.*

#### 2-D Version

- ★ Trace ball pattern onto craft foam.
- ★ Cut out, and decorate with permanent markers.
- ★ Sand the top of a milk bottle cap.
- ★ Punch 2 holes (one on left and one on right side of the cap)
- ★ Tacky glue the foam ball to the milk bottle cap.
- ★ Thread half of a chenille stem through the holes.
- ★ Twist the ends around each other to create the loop for the tie slide.

#### Alternatively,

Glue the foam ball to a circle of corrugated cardboard that is cut a little smaller than the ball. Make sure the corrugations are going horizontally.

Push half a chenille stem through the corrugation channel going across the middle of the ball. Fold the ends of the stem over, so they are behind the ball. Leaving a little space between the cardboard and the stem (so the neckerchief can fit), twist the chenille stem ends around each other, and flatten to create the loop.

Or cut a ring from the handle of a milk jug. Roughen the flat side with a file, and glue the flat side to the cardboard.  
Or use 1/2" PVC pipe.

*Boys could make baseball, football, basketball, tennis, soccer, golf ball, tie slides. Wendy*

## Flag Activities

### American Flag Tie Slide Wendy, Chief Seattle Council

#### Materials:

3 parts white glue to 1 part warm water  
jar or bottle with screw top lid  
balsa wood or cardboard  
1/2" length of 5/8" PVC pipe  
US Flag postage stamp or picture from a magazine  
paint brush  
glue

*Note - few years ago, the USPS issued stamps of all 50 state flags. If you find one (google it!) then copy it, these can be used in lieu of US Flags. CD*

#### Directions

1. Combine glue with water in jar or bottle. Shake until well mixed. This glue may be stored indefinitely.
2. Cut a piece of balsa wood or cardboard large enough to hold the selected picture.
3. Brush a thin layer of glue to the back surface of the picture. Lay the design onto the cardboard or wood and smooth out all air bubbles and wrinkles.
4. Let dry.
5. Glue the ring of PVC pipe to the back to the form the slide.

Alternate, loop if using cardboard

- ✓ Make sure the corrugations are running horizontally.
- ✓ Decorate cardboard if desired.
- ✓ To make a ring for the tie slide push half a chenille stem through the middle corrugation, and wrap ends around each other to make a ring,

#### Wind Star:

*Wendy, Chief Seattle Council*

- ✓ Cut 5 strips from the short end of a white poster board, about 1 1/2" wide.
- ✓ Lay the strips in a star shape.
- ✓ Use clothes pins to clamp the points of the star together so it doesn't shift while you glue it together.
- ✓ Use tacky glue to glue the points and center of the strips where they cross each other.
- ✓ Cut 1 inch strips from the edge of inexpensive plastic red, white, and blue tablecloths.
- ✓ Tape the strips to the bottom of the poster board star.
- ✓ Use foam core board or corrugated plastic for the star if the wind star is hung outside.

## First Aid Activities

### Mini First Aid Kit I

*(Wolf Outdoor Activity Award)*



**Materials to build it**

Plastic Film Canister or Pill Bottle  
Label  
Paint/markers  
PVC Ring (If making a neckerchief slide)  
Hot Glue

**First Aid Supplies**

Two Gloves  
1 2"x2" gauze bandage  
Medical tape (roll a 2' length on a straw)  
2 quarters  
3 Band-Aids

**Directions**

- If you can find supplies that are small enough, you can fit it all in one film canister. Otherwise, glue two lids together and let dry.
- Attach a ring to the canister with hot glue.
- Make a label for the front with either "First Aid Kit" or the symbol for first aid, a red cross.
- Put items inside canisters.

**Mini First Aid Kit II**

Recycle a film canister (or pill bottle) and transform it into a handy Mini First Aid Kit for kids to wear on their belt.

**What you'll need:**

Fuji film canister  
Scissors  
Colored pony bead  
First Aid or Cub Scout sticker  
Plastic lanyard (Gimp)  
Midget Tootsie Rolls  
Alcohol swab  
Band-Aid  
Q-tip  
Hot glue or "Glue Dots" (A & W Products)

**How to make it:**

1. Adhere the pony bead to the top of the film canister using either hot glue or Glue Dots.
2. Place a sticker on outside of canister.
3. Lace the plastic lanyard through lid.
4. Tie a knot. You can also use a hole punch and punch 2 holes in the lid then string the lanyard through.
5. Tie a knot.
6. Cut a Q-tip in half.
7. Put Tootsie Rolls, alcohol swab, a Band-Aid, 1/2 Q-Tip inside the canister. Secure the lid.
8. Put your Mini First Aid Kit on your belt. If you get hurt or lost from the group, clean the spot with the alcohol wipe, put on a Band-Aid, and eat a Tootsie Roll.

For another idea on this item see -

[http://www.makingfriends.com/lanyard\\_firstaidkit.htm](http://www.makingfriends.com/lanyard_firstaidkit.htm)

For more things to make with Film Canisters or Pill Bottles go to [The Film Can Page](#)

**Bike Activities****Road Signs**

*Wendy, Chief Seattle Council*

Take bike rides to the next level and help your Scouts learn the rules of the road by making traffic signs.

**Materials**

Road sign templates  
Pencil  
Colorful craft foam  
Scissors  
Paintbrush  
White and black acrylic paints  
Craft glue  
Plastic containers with lids (such as margarine tubs)  
Sand  
Craft knife  
3- to 4-foot wooden dowels

**Instructions**

- Download the road signs:
 

<a href="#">GO</a>	<a href="#">SLOW</a>
<a href="#">STOP</a>	<a href="#">STRAIGHT</a>
<a href="#">TURN</a>	<a href="#">WALK</a>
<a href="#">YIELD</a>	
- Trace each template and design on to 2 pieces of craft foam. Cut out a pair of matching sign shapes, then paint the designs with white or black paint.
- Pint-Sized Road Signs - Step 3 Glue the shapes together back-to-back along the edges, leaving a 2-inch opening at the bottom, then let them dry.
- Fill a container with sand, then replace the lid and use a craft knife to cut an X in its center (parents only). Push a dowel through the lid, then set the sign atop the dowel.

**Bike Bling**

*Wendy, Chief Seattle Council*

Learn how to make your bike parade ready. Decorate it with Red, White, and Blue. Check this website for ideas:

<http://jas.familyfun.go.com/arts-and-crafts?page=CraftDisplay&craftid=10104>

**Embossed Pop Can License Plates**

*Adapted from '07-'08 Program Helps, Jan-10)*

*Wendy, Chief Seattle Council*

1. Cut the tops and bottoms off pop cans with scissors. Cut up the long side of the cylinder. This will yield a curled rectangle of aluminum.
2. Flatten the aluminum by pulling it gently over the corner of a table or counter. If you scrub off the color with steel wool, the boys will have an easier time seeing their embossed design when they work on the back side of the aluminum.

This can also be done with different colors of craft foam, glue, glitter, and miscellaneous craft objects decorating the license plates.

Precut foam pieces in half and make a frame out of the half or buy precut foam frames. The boys will need to glue the frame to a half sheet of foam.

3. Draw numbers and letters with a ball point pen, orange stick, or embossing tool, pushing hard. To raise the numbers and letters, (mountain), work on the back side (colored side) of the aluminum. To create an indented line around the numbers and letters, work on the front of the aluminum (valley). The raised portions of the plate will look best if they are outlined by indented (valley) lines.

They can then put their name on the license plate and decorate it in any fashion they want. Challenge the Cub Scouts to make vanity plates. Boys can create fun abbreviations and then have others guess what they are.

**Examples:**

IML8 = I am late  
 IM4U = I'm for you  
 2Fun = Too fun  
 4tun8 = Fortunate

4. Instead of drawing numbers & letters, the boys could draw pictures on their decorator plates.
5. Color the plates using permanent markers.

**Bike Rodeo**

*Santa Clara County Council*

Here are some ideas for you do run a bike rodeo for your Cub Scouts. The boys and their parents need to be involved in this fun activity. Include traffic safety, bike safety, and bike skills in the activities you choose for the event. **Your local Police Department can probably provide you with complete details on running this event.**

The rodeo should encourage the safety, bike skills and confidence a Cub needs to ride safely. A bicycle is a vehicle with the same rights and responsibilities as other vehicles on the roads. Biking is fun. In order for Cubs to know if their bikes are safe, contact your local police department. Many will send an officer out to do a bike safety checks. Stress the need to of bike safely - not foolishly. Instill good traffic habits from the start with young riders.

Once a boy learns to ride a bike, he will never forget. If he learns good riding skills when he is young, they will follow him into adulthood. Bicycling is truly a life-long activity.

**Equipment:**

- 50 feet measurer or yard stick
- Chalk, tape or sting - for lines
- Traffic cones or weighted cans
- Score sheets and pencils
- Clipboards - for volunteers
- Stop Sign
- Bicycles and helmets

**Organize** so there is as little waiting as possible.

**Divide** the Cub Scouts and rotate them through the different areas.

**Station One: Inspection Station** – The Cub Scout needs to have his bike checked for safety. Ask your local policeman to come and check the bike.

**Station Two: Ride on the line** – Make a wide line and have the Cub Scout ride his bike down the line. The line should be no longer than 12 feet.

**Station Three: Helmet and bike check** –Check the helmet fit and seat height. Know how to use a lock and cable to secure a bike.

**Station Four: Safe Driving** - Have the Cub Scouts ride their bikes around traffic cones. The leaders can choose the pattern of the cones.

**Station Five: On the Street** - Create an intersection on the parking lot. Have the Cub Scouts demonstrate how to cross an intersection safely.

**Station Six: Steering** - Make a circle with the tape. Have the Cub Scouts ride their bike around the circle, staying on the tape as much as possible.

**Station Seven: - Recognition** - Cub Scouts receive recognition for rodeo participation and have a snack.

**Fun on Wheels Rodeo**

*Trapper Trails*

How about a bike rodeo this month?? –

Obstacle course, hand signal test, races, safety check, best decorated bike contest. Farmer Insurance representatives have great pamphlets. Local police are a great resource.

A bicycle rodeo is designed to promote bicycle safety and test specific skills on a designated course. Safety and skills can be easily adapted for skateboards, roller blades, and scooters.

This event can be held at a pack level, involving families, and a representative from the local police department to conduct the bicycle inspection and safety review. Or a den can hold a bike rodeo with just a little ingenuity, sidewalk chalk or empty cans to mark the course, and an open area. Every boy should bring his own bicycle, scooter, etc. All boys must wear a helmet whenever they are riding a bicycle.

**Bicycle Inspection:** -- Check the size and condition of your child's bicycle.

- ✓ **Size:** Children should be able to stand flat footed over the bicycle with at least one inch between the bicycle's top tube (boy's bicycle) and the rider. Inexperienced riders should be able to put both feet on the ground while sitting on the seat. For more experienced riders, the legs should be just slightly bent at the bottom of the pedal stroke with the ball of the foot on the pedal. The bicycle seat should be level and not tilted forward or backward.
- ✓ **Brakes:** Coaster brakes - Push the bike forward while pushing back on one pedal; the rear tire should skid. Make sure the brake arm is attached to the frame at the rear wheel. Hand brakes - ensure brake pads are not worn and that they hit the wheels evenly. The brake levers should work smoothly and have one inch of clearance from the handlebars when the brakes are fully applied.

- ✓ **Wheels and Tires:** Check to see if the handlebars are tightly fastened by holding the front wheel between your legs and trying to turn the handlebars to the side. If they move, the bolt at the handlebar stem needs to be tightened.
- ✓ **Frame and Fork:** Check the frame and fork (the metal arms on either side of the front wheel) for basic straightness. If the frame or fork are not straight, or are cracked, bring it to your local bike shop for repair.

This list is an overview of the most basic elements of bicycle maintenance. If you suspect that your bicycle is not working properly, bring it to your local bicycle repair shop for further inspection and repair.

**Skills:** (The course design on p. 6-12 in the Cub Scout Leaders How To Book is a clear illustration)

1. **Start:** Mount the bike and coast, while turning your head to the left and right— but not the bike.
2. **Intersection:** Use arm signals. Obey traffic lights and sign. Mark out an intersection 6 feet from corner to corner. Make stop signs from cardboard cut into an octagon and painted. Make signal lights from holiday lights or lamps with colored cellophane coverings.
3. **Steering course.** Mark out a straight path 4 feet wide and 30 feet long. This tests your ability to hold a straight course. Ride at a comfortable speed.
4. **Circle riding:** Mark out a figure eight with the circles having exterior diameters of 29 feet and a path 2-3 feet wide. Ride the figure eight 1 ½ times.
5. **Steering Control / Zigzag Course.** Place empty cans or cartons at 10 foot intervals in a straight line. Steer to the right of the first can, to the left of the second, to the right of the third and so forth. This tests your ability to shift balance while changing direction.
6. **Riding the Spiral:** Draw a large spiral on the ground (about 20 feet across) with the lines spaced 30" apart as they progress toward the center; mark an X at the center point. Ride at any speed, trying not to touch the lines. Place your foot down at the X.
7. **Braking Area:** Set up flags or cans at regular intervals (or mark lines across a straight course) Keep pedaling at a comfortable speed until a whistle blows. Then stop without skidding. The leader should blow the whistle when the rider is even with any flag. The rider should stop before the next flag (or measure the stopping distance with a tape measure).
8. **Speed Area:** Mark a straight course or a course with curves. Ride as slowly as possible, keeping your balance on the bike.

### Helmets and Clothing

From: [www.cpsc.gov](http://www.cpsc.gov)

Do you know the correct way to wear a helmet?

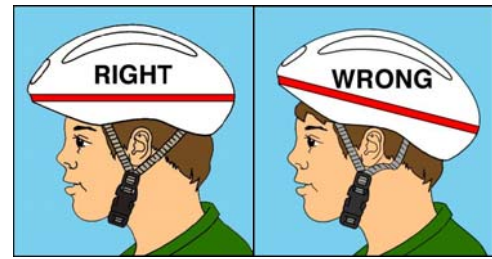

Wear the helmet flat atop your head, not tilted back at an angle!



Make sure the helmet fits snugly and does not obstruct your field of vision. Make sure the chin strap fits securely and that the buckle stays fastened.

Check our [recall link](#) to make sure your bicycle helmet has not been recalled.

### It makes sense to wear something brightly colored when you're biking.

Choose a color that makes you easy to see. If you're biking in the forest, don't wear green!

- ✓ Fluorescent green, yellow or orange are all great choices. If you're wearing these colors, other bikers, motorists and pedestrians will be able to see you better.
- ✓ Look for fabrics that are cool and lightweight. (You can really work up a sweat biking!) If it's cool outside, dress in layers. You can peel off clothing as you start to get warmer.
- ✓ For riding at night (which we don't recommend for anyone) you'll need clothing with retro-reflective materials sewn onto it. You'll also need one light source, like a headlamp.
- ✓ Make sure the straps of your bookbag, loose clothing or anything else isn't going to catch in the wheels of the bike, and cause you to lose control.
- ✓ Last but not least -- don't forget to wear your helmet!

### What not to wear while you're biking.

- ✓ Headphones are a no-no! You won't be able to hear what's going on around you.
- ✓ Clothing that's too loose.
- ✓ Inappropriate shoes. (High-heels, Slippers, Bowling Shoes)
- ✓ Dark Clothes

**The Melon Drop**

*Alice, CS RT Commissioner*

*Pioneer District, Golden Empire Council*

Looking for a dramatic demo for your next group talk to kids? So was Dr. Hal Fenner of the Snell Foundation. He has tested various melons for dropping to the floor, one in a helmet and the other bare. Hal has concluded that the best melon is a not-too-ripe honeydew. Pumpkins can be better, but finding head-sized ones is difficult.

Take your helmets to the grocery to find the right size honeydew. Shaking the melon tells you which is ripe--you can hear the seeds rattle in a ripe honeydew, so avoid the noisy ones.

Draw smiley faces, or one smiley and one pfffft face on the melons. Hold the helmeted and unhelmeted melons out to your sides, one in each hand, and tip your hands toward the audience to drop them in unison. The unhelmeted honeydew will smash. Whee. The helmet on the other melon will last for three drops, then split on the fourth one, still preventing the melon from smashing.

Hal reports that the kids are impressed, and you have their attention right away.

**Personal Bike Rack**

*Santa Clara County Council*

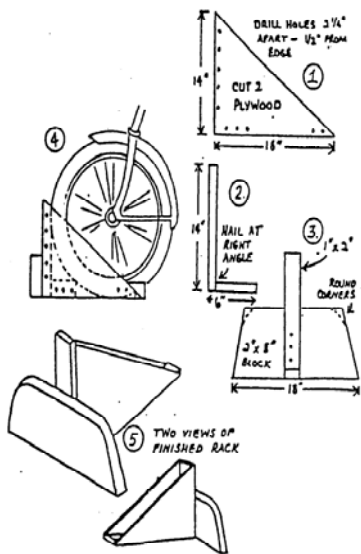

**Materials:**

- One 14" x 18" piece of 1/2" plywood;
- One 1" x 2" x 2"; one 2" x 8" x 18"
- No. 6 flathead screws (1-1/4" long);
- Six-penny nails;
- Varnish or paint;
- White glue or powdered resin glue.

**Directions:**

1. Cut plywood triangles. Drill holes as show with a 5/32" drill bit. Paint or varnish the inside of plywood at this time. It will be difficult to do after rack is assembled.
2. Cut the 1" x 2" pieces. Nail the two longest pieces at right angles.
3. Cut the 2" x 8" piece. Attach the nailed 1"x2" with screws. Paint or varnish the 1" x 2" now. (Note the right angle is fastened to the 2" x 8" with screws from inside.)

4. Fasten the plywood triangles in place with screws through pre-drilled holes. Don't forget the small piece of 1" x 2" that joins the tips of the triangle.
5. Sand and complete paint or varnishing the piece.

**Three Bike Rack**

*Alice, CS RT Commissioner*

*Pioneer District, Golden Empire Council*

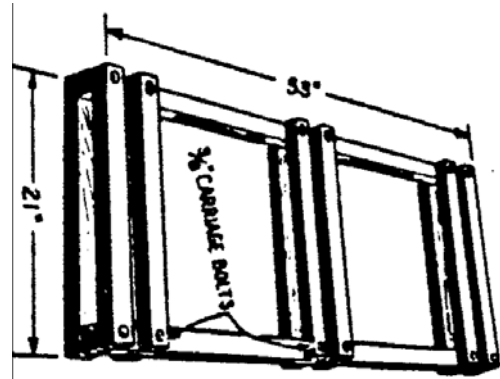

**Materials**

- 2" by 2" lumber
- 3/8" carriage bolts

**Directions**

- ✓ Cut 2x2's using measurements given on picture:
  - 2 pieces 53" long, and 12 pieces 21" long for a 3 bike rack, or
  - Half the length and 8 cross pieces for a 2 bike rack.
- ✓ Glue the crosspieces in place on the side pieces for stability,
- ✓ Make sure cross pieces and side pieces are square.
- ✓ They should be a tire width plus 1/8 inch apart.
- ✓ Then bolt the crosspieces thru the side pieces as shown, using carriage bolts. (Pre-drilling a starter hole to prevent splitting the wood is recommended)
- ✓ If rack will be on ground (dirt) bolts may protrude to help anchor rack
- ✓ If rack will be on pavement, make bolts flush on bottom.

**Bicycle Safety Quiz**

*Santa Clara County Council*

See how well you know your bicycle safety facts by taking this quiz. Circle the letter for the answer you choose.

1. When approaching a stop sign, I should:
  - a) Look left and right and ride through the intersection without slowing down.
  - b) Slow down and then proceed through the intersection.
  - c) Come to a complete stop, check both directions and then proceed when it is safe.
2. When approaching an intersection with no stop sign or light, the best thing to do is:
  - a) Ride through quickly.
  - b) Slow down, look to the left and right, and watch for tuning vehicles.
  - c) Stop in the middle of the road to see what's coming.

3. When making a turn or stopping on the road, I should use hand signals:
  - a) When a big steamroller is approaching.
  - b) If Mom is watching.
  - c) Every time I turn or stop.
4. On two-way city streets as well as country roads, I should ride on the \_\_\_\_\_ side of the street.
  - a) Left – against traffic
  - b) Right – with traffic
  - c) Left or right, whichever is more convenient
5. When is it okay to carry another person on my bicycle?
  - a) Never.
  - b) If there's not much traffic.
  - c) If I stay on the sidewalk.
6. If I am late starting home after dark and my light doesn't work, I should
  - a) Walk my bike home on the sidewalk.
  - b) Ride on the left side of the street to see cars coming.
  - c) Ride on the right-hand side of the street.
7. Good ways to be seen at night are by:
  - a) Wearing light-colored clothing and reflective tape.
  - b) Using bright reflectors, red to the rear, white or amber to the side, and white to the front.
  - c) Both A and B.
8. The safest way to carry books or other gear on my bicycle is:
  - a) In pack on my back.
  - b) In a special carrier rack or basket.
  - c) In a bag in my hand.
9. Leaves on the roadway and painted center lines can be hazardous to cyclists because:
  - a) They distract your attention.
  - b) They become slippery when wet.
  - c) They may both be yellow-colored.
10. A good rule when riding in traffic is:
  - a) To listen as well as watch for cars.
  - b) To weave in and out of parked cars.
  - c) To yell at motorists who are in your way.
11. If I approach a crosswalk when riding my bike, I should:
  - a) Yell so pedestrians will get out of my way.
  - b) Stop so that pedestrians may cross.
  - c) Ride my bike up the curb to avoid hitting anybody.
12. When bicycling with a friend, we should always ride:
  - a) Single file.
  - b) Two abreast.
  - c) In no particular pattern.
13. When riding with a group it is best to:
  - a) Tie a rope to the first rider and hang on.
  - b) Ride a little to one side of the rider ahead and overlap wheels.
  - c) Ride a safe distance behind the rider ahead in a single file.

2. Bicycle drivers should obey all traffic signs and signals.
3. Stop signs are round in shape.
4. Pedestrians have the right-of-way on sidewalks and crosswalks.
5. Bicycles should be "walked" across busy streets.
6. The signal for a right turn is stretching the right arm straight out.
7. Driving a bicycle at night without a front light or rear reflector is unsafe.
8. It's safe for a bicycle driver to carry a passenger.
9. You don't have to stop at an intersection if there is no traffic.
10. Hitching a ride on another vehicle is safe if the driver is careful.
11. Bicycle drivers should give a hand signal before making a turn or stopping on the street.
12. It's safe to drive a bicycle that is in poor condition if you are a good driver.
13. If you're driving bicycles with friends, you should go single file.
14. Your chain should be loose enough to slip off easily.
15. It's okay to drive a bike in either direction on a one-way street.
16. If you live in the country, it's okay to drive on either side of the road.
17. Even a good driver should "walk" his bicycle through heavy traffic.
18. The faster you drive, the safer it is.
19. Bicycle drivers should stay at least three feet away from parked cars.
20. If you don't ride on busy streets, you don't need a horn or bell.

**Answers –**

- |          |                     |                     |           |
|----------|---------------------|---------------------|-----------|
| 1. True  | 2. True             | 3. False (See note) | 4. True   |
| 5. True  | 6. False (See note) | 7. True             | 8. False  |
| 9. False | 10. False           | 11. True            | 12. False |
| 13. True | 14. False           | 15. False           | 16. False |
| 17. True | 18. False           | 19. True            | 20. False |
- #3 – Stop signs have 8 sides.  
 Railroad crossing signs are round.
- #6 – For a right turn, it's extending the left arm with forearm raised and the palm of the hand facing forward.

**MORE GAMES AND ACTIVITIES**

*Wendy, Chief Seattle Council*



- ✓ Useful items from the how-To Book are referenced throughout Baloo's Bugle.

Want to check something in the "How To Book," and your copy is not available?? Want to copy something quick to use at a meeting?? You can find the "How To Book" at this address on **National's Web Site** - [http://www.scouting.org/filestore/hispanic/english/33832\\_WEB.pdf](http://www.scouting.org/filestore/hispanic/english/33832_WEB.pdf)

*Answers -*

*1c, 2b, 3c, 4b, 5a, 6a, 7c, 8b, 9b, 10a, 11b, 12a, 13c*

**True or False Safe Driving Quiz**  
*Santa Clara County Council*

1. A bicycle should be driven on the right-hand side of a street or highway.

## ADVANCEMENT IDEAS

*Alice, Golden Empire Council*

As a new scouting year begins, Boys can take responsibility for completing the Bobcat or helping another boy earn his. Parents can help teach responsibility by example by making sure to read and discuss the first section of each rank's book. Den Leaders model responsibility by taking time to plan their meetings, being on time, and going the "Extra Mile." We can also point out both opportunities to be responsible, and examples of boys who are being responsible. Change your perspective and look at Responsibility from a boy's view – find everyday ways boys can practice it!

With the new delivery plan, Achievements and Electives have been largely assigned in separate meetings the Den Leader chooses, but there are often some requirements that could help to support the Value for the month. Here are some activities to support the value of Responsibility – the Character Connection has been underlined and marked with an (\*) asterisk for each rank.

### Tiger Achievements

**Ach. #1F – Character Connection for Responsibility**, and choosing a chore to do with the adult partner – be sure to check the Note to Adult Partner; **Ach. #1G** – If visiting a library, look for a book about responsibility or chores (ask the children's librarian), or if visiting a farm or museum, look for examples of how people shared responsibilities and did chores to help their family. (Think outside the box – some relatives may take on responsibility for keeping family history or photographs)

**Ach. #2G** – If you visit a fire station to celebrate National Fire Safety Month, ask firefighters about their responsibilities – also ask about how people, including Tiger Cubs, can be responsible to help prevent or deal with fires and their aftermath. They might share ideas about using "911" responsibly, keeping smoke alarms in working order, and what to do in case of a home fire.

**Ach. #3F** – Boys can be responsible to help their families plan and practice a safe fire escape from their home. They could also help check out the home and school for potential fire dangers. See Web Sites or check with your local fire department for brochures, information. **Ach. #3D** – Each boy can take responsibility for looking through old magazines and cutting out pictures of food, and learning where they would go on the Food Pyramid.

**Ach. #3G** – Each boy should take responsibility for his behavior if attending a game – review good sportsmanship, not leaving trash behind, and being a "good neighbor" to others at the game. (This could be a chance to begin work on the Good Manners Belt Loop)

**Ach. #5D** – If you take advantage of Fall color to do leaf rubbing, be sure and talk about being responsible – collect only fallen leaves, don't disturb animals and their homes, and pick up and dispose of any trash properly.

### Tiger Electives

**Elect. #5** – Anytime the boys take a hike, remind them of being responsible to pick up their own trash, stay on trails, respect boundaries and the homes of others, (including

animals), and have good outdoor manners so everyone can enjoy being outside in nature.

**Elect. #9** – Ask boys to share experiences about helping someone new to the neighborhood, pack or class to feel welcome. Talk about how each boy could help a new scout complete his Bobcat. **Elect. #14** – Read about Responsibility or Fire Safety, or about Disabilities – look for stories about people who have overcome their challenges.

**Elect. #21** – You could prepare puppets and do a short show about Responsibility, Fire Safety, Disability Awareness, or even Good Manners.

**Elect. #24** – Help an adult prepare a family meal and take responsibility to clean up afterwards

**Elect. #25** – Make a snack to share with family or your den – check the ideas in Cub Grub

**Elect. #26** – Take responsibility to learn and practice how to use good phone manners and take good messages

**Elect. #27** – Talk with adult partner to know what to do in an emergency.

**Elect. #28** – Check smoke alarm batteries with your adult partner – see calendar idea in Theme Related

**Elect. #32** – If you make a bird feeder, remember that you are responsible to make sure it gets refilled

**Elect. #33** – With your den or family have a Cleanup Treasure Hunt

**Elect. #34** – Think of a way to conserve water or electricity and do it for one week

**Elect. #47** – Learn about recycling and help your family do it properly.

### Wolf Achievements

**Ach. #2a** – Use a dictionary or thesaurus to help you understand the meaning of the Pledge of Allegiance; take responsibility to always do it with respect. **Ach. #2c** – Take responsibility to show how to respect and display the flag, and to always be a good example to others. **Ach. #2d** – Learn about your state flag, and be responsible for displaying it properly with other flags. **Ach. #2e, f** – Learn about the correct way to do an outdoor ceremony, then take responsibility for doing it properly and showing others how to be a part of an outdoor ceremony – remember to focus on the flag and be quiet and respectful even if you are in the audience. **Ach. #2g** – learn to fold the flag properly, then be responsible to practice so you can do it with only the stars showing. This would be a great gathering activity.

**Ach. #3a** – Take responsibility to keep a health chart for two weeks and turn it to your leader – see a sample under Theme Related Ideas. **Ach. #3b** – Each boy can be responsible to protect others from their sneezes or coughs – teach them the "Cafeteria Cough" – to always turn to the side and cough into their inside elbow. Food workers must do this to protect against getting germs on their hands and then using their hands while working with food. **Ach. #3c** – Remind boys to be responsible for telling an adult about a cut right away so it can be handled properly.

**Ach. #4a** – Be responsible for emergency numbers near each phone – and know how to use "911" responsibly. **Ach. #4d**



– Be responsible to help make sure your home is secure before you leave, and to take everything you need. **Ach. #4e**  
 – Talk with family members about what jobs you will do, then make a list and mark them off when finished – do this for a month. *Being responsible means you don't have to be reminded over and over to the job!*

**Ach. #7c, d, f** – Take responsibility to recycle, pick up litter and help save energy.

**Ach. #8c** – Help fix at least one meal for your family, from setting the table to washing the dishes and clean up. **Ach. #8d** – Fix your own breakfast and wash and put away the dishes

**Ach. #9a** – Complete the **Character Connection for Responsibility**; you could also do **Ach. #9b,c** – to check for fire and safety hazards in your home and make your home safe.

**Ach. #10a** – if you go bowling and work on that belt loop.

**Ach. #10f** - If you go to a concert, play or live program with your family, be responsible for having good manners.

### Wolf Electives

**Elect. #1c** – If you celebrate Disability Awareness Month, you could learn to sign your name in ASL; as you work on the patch, remember to take responsibility for showing proper respect

**Elect. #2** – do any or all of the requirements if you do a skit about Responsibility, Disability Awareness, Fire Safety or Keeping Your Body Healthy

**Elect. #3** – Take responsibility to make and play games with younger children

**Elect. #6 b,c** – Take care of library books and be responsible to mark your calendar so you return them on time; help protect your own books with covers and by opening them the right way. Don't write in books or crimp the corners – be responsible!

**Elect. #9a** – Take responsibility to help with a party at your home or in your den – help decorate, serve refreshments and clean up.

**Elect. #11a or b** – Learn and sing “America” or the national anthem – be responsible for singing it as part of a flag ceremony with your den

**Elect. #13e** - If you feed wild birds, be responsible to keep the feeders filled, especially during the colder months of the year when natural food is scarce

**Elect. 14** – Be responsible to take good care of a your pet, read a book about your pet, and know what to do about strange dogs or possibly rabid animals.

**Elect. #16a, b** – Talk with your family about what to do in an emergency, and be responsible for knowing how to shut off water, electricity, and gas if you need to do it.

**Elect. #18a,b** – Help plan and hold a picnic or outing with your family or den.

**Elect. 20** – be responsible to learn and practice the safety rules of any sport you take part in, such as bowling basics if your pack goes bowling.

**Elect. 20e** – take responsibility for helping a boy join scouts or finish his Bobcat

**Elect. #23b, c** – Know and explain the basics of how to take care of yourself in the outdoors; tell what to do if you get lost

### Bear Achievements

**Ach. #1b** – Make a list of things you can do to practice your religion; check them off your list as you do them – be responsible for looking in the workbook for your faith's religious emblem for ideas.

**Ach. #6 a** – Be responsible to help sort and recycle trash at your home

**Ach. #7c, d** – be responsible for learning about how you can help prevent crime and secure your home and belongings; be sure you know where to get help in your neighborhood; know what you can do (and should not do) to help law enforcement; **Ach. #7e** – Learn local emergency phone numbers and post them by each phone; learn how to use “911” responsibly, and practice how to make an emergency call and give the right information

**Ach. #9b,e, f** – With an adult, make snacks for a den meeting; trail food for a hike, or dessert for your family – and clean up afterwards! **Ach. #9c** – With an adult, prepare part of your breakfast, lunch and dinner – Cleaning up is part of being Responsible!

**Ach. #11a** – Know what to do in case of an accident in the home. **Ach. #11e** – With your family, plan and practice a home escape drill.

**Ach. #12b** – Go on a hike with your family, and be Responsible for knowing the safety rules and what to do if lost, BEFORE you go on a hike

**Ach. #13b, c** – Set up a savings account; Keep a record of how you spend your money for 2 weeks, so you can be responsible for knowing where your money goes.

**Ach. #14** – Be responsible for learning and practicing rules of safe riding, always wearing your helmet the RIGHT way, learning and practicing bike skills, and being responsible for knowing how to care for your bike and protect it from theft.

**Ach. #18a, c** - Make a “to-do” list and check off each item; keep a daily record of what you do for two weeks – be responsible for using your time wisely! **Ach. #18e** – Write a thank you note to someone.

**Ach. #19a, b, d** - Show that you are responsible by learning the rules for knife safety, how to take care of a pocketknife, and earning the Whittling Chip card.

**Ach. #20** – Show that you know how to use and take care of at least four HAND tools; Build your own toolbox and use two tools to fix something.

**Ach. #23e** – If you attend a sporting event, take responsibility for showing good sportsmanship and manners.

**Ach. #24a, b, c** - Be responsible for helping a new boy join scouting or complete his Bobcat; serve as a denner or assistant denner; plan and conduct a den activity with your den leader's approval.

### Bear Electives

**Elect. #14a** – With an adult, help take care of a lawn or flower bed at home or at a church, home or public building; pick up litter; weed and prepare beds for winter. **Elect. #14c**

– Take part in a project with family, den or pack to beautify or clean up your neighborhood or community – be responsible for your behavior and for completing the job

**Elect. #17** – With the help of an adult, take responsibility to do any or all of the requirements listed.

**Elect. #21a, b** – Be responsible to keep track of your own sales if you take part in a den, pack or council fund raiser; or help with a garage sale for your family, neighbor, school, church or pack.

**Elect. #22** – Take responsibility for sorting and displaying your collection; keep your own library in order and store the subject information so it can be used

**Elect. #25a, b** – Learn about and assemble ten essential items you need for a hike or campout; follow the buddy system and know the rules to follow if lost

### Webelos Activity Pins

Whatever pin a Webelos Scout works on, he should feel responsible for taking care of the equipment, returning supplies to the right place, and cleaning up the area when he is done. Den Leaders can help encourage responsibility by positive comments whenever this is done, and by personal example.

**Artist #1** – Talk to an artist about different occupations; be responsible for having good manners and showing interest in various kinds of art that may seem unfamiliar to you.

**Athlete #4** – Be responsible to always start with stretching exercises to help prevent injury; **Athlete #5 – 9** – Be responsible for following the program and doing the activities for a 30 day period to track improvement.

**Citizen #3, 4, 7, 9** – Show that you know how to hoist and lower the flag, display, retrieve and retire it properly, and how and when to display the flag; Explain the rights and duties of a citizen; know how you can help law enforcement agencies

**Communicator #9, #10** – During Disability Awareness Month, invite a person with visual, speaking or hearing impairment to visit the den and learn about special ways they communicate and how you can communicate with them; Or invite a person who is bi-lingual to visit the den and discuss familiar words and how to learn another language Talk about ways to be responsible for good manners and showing respect.

**Craftsman #1** – Show that you can safely handle tools, and be responsible for taking care of them, putting them away properly, and cleaning up the area.

**Family Member #1-6** Take responsibility for learning about and helping with family jobs, budget and spending, family meetings and inspecting your home for safety and security.

**Family Member #7, 9, 10, 11** – Take responsibility for helping prepare an energy saving plan; learning how to clean your home and doing it for a month; taking care of your own clothes and helping with family laundry; helping plan meals, buy and prepare three family meals

**Fitness #3, 4, 8** – If it has not been completed, plan a week of meals with a family member, using meal planning information in the Webelos book; keep a record of your meals and snacks for a week and decide if they have been good choices; Be responsible for reading “Take a Stand Against Drugs” and

discuss it with an adult, showing that you understand the material.

**Handyman #1** – Complete **Character Connection for Responsibility** and do any six of the suggested activities (#1-17) - and make sure to be responsible for taking care of the tools and cleaning up the mess!

**Readyman #3, 4, 5, 6, 7, 11, 14** – Be Responsible for making a “help” list for emergencies; Learn and show how to do various first aid procedures; Make a home fire escape plan for your family; Explain six safety rules to remember when riding in a car.

**Showman #2, 3, 4, 5** – Put on a puppet show about Responsibility, Disability Awareness, or Fire Safety.

**Showman #16** – Give a talk on a subject of your choice – how about Responsibility?

## GAMES

*I had an error in this section last month. I said to use Helium. It does not use helium. Just do as it says. For more info google "Helium Stick" and you get lots of hits. This is a really neat trick. Check it out!!! CD*

### Helium Hoop or Pole

*Scouter Jim, Great Salt Lake Council*

#### Equipment -

Pole or Hoop

Hoop

**Number of People:** 6 or more

#### Description:

- ★ Present the group with the hula hoop or pole.
- ★ Tell them they must lower the hoop (or pole) to the ground quickly and evenly.
- ★ Each member must hold out a finger on each hand.
- ★ Those fingers must maintain contact with the bottom of the hoop (or pole) at all times.
- ★ Hands must stay parallel with the ground and participants cannot hook the hoop/pole.
- ★ The second the facilitator lets go of the hoop/pole it will start to rise and the participants will start blaming each other. Because it is so lightweight the participants keep trying to push up in order to maintain contact with it.

With everyone having the same idea the hoop will rise upward like magic. It's really funny to see the reactions to this phenomenon. I put my scouts through some physical activities prior to using this one. They think it's going to be simple and end up going mad. It's a great activity for going over communication and placing blame. As an added challenge I'll have them lower the hoop around a small orange cone. With a pirate theme the hoop is a key to a magical lock (the cone). I usually place something under the cone that ties to the next activity.

**Responsibility Exercise Game***Catalina Council*

For this exercise, you stand up when it's your turn to talk.

You sit down when you aren't talking. Break the boys into two groups.

Group #1: One, Two!

Group #2: Do your best in all you do!

Group #1: Three, Four!

Group #2: Do your part then do some more!

Group #1: Five, Six!

Group #2: Don't blame others for your fix!

Group #1: Seven, Eight!

Group #2: Set a good example and be first rate.

Group #1: Nine, Ten!

Group #2: Make a mistake so try again!

Now reverse groups.

Group #1 becomes Group #2 and vice versa.

Now do the same thing but faster.

Keep switching groups and increasing the speed.

*I think this could be easily adopted to an opening ceremony or a cheer!!! CD*

**Responsibility Do's and Don'ts Game***Catalina Council*

See how many Do's and Don'ts the boys can come up with in a five minute time frame.

After you have the list (or use list below) below, turn it into a game of charades have the boys take turns acting out each do or don't. Maybe they can create a special sign to tell whether it is a DO or a DON'T.

**Responsibility Do's:**

- ☺ Think before you act.
- ☺ Think before you talk.
- ☺ Do only good things.
- ☺ Think about what will happen if you say or do what you want to say or do.
- ☺ Fix your mistakes. Clean up your own messes.
- ☺ Be a good example.
- ☺ Think of ways to help others.
- ☺ Do your jobs.
- ☺ Do your best.
- ☺ Keep trying.
- ☺ Finish your work before you play.

**Responsibility Don'ts:**

- ✗ Don't do anything before you think.
- ✗ Don't say anything before you think.
- ✗ Don't do anything that's bad or wrong.
- ✗ Don't blame others for your mistakes.
- ✗ Don't leave mistakes or messes for others to fix.
- ✗ Don't wait for someone to tell you to do good things.
- ✗ Don't do anything that you won't be proud of.
- ✗ Don't play until you finish your work.
- ✗ Don't pretend to have done jobs you haven't done.

**Letter and Word Game***Catalina Council*

Divide the boys into teams of four or five. When you announce a letter of the alphabet, let each team arrange itself on the floor in the shape of the letter, using every team member.

Discuss responsibility by asking, "What would we have had if (one of the boys) were not in place?"

Repeat the activity and praise everyone for doing his part to make the letters. If you have enough boys, let them work as one big team to arrange themselves into simple words, such as: "do," "best," "good," "finish," "action," "words," "control," "duty," "right" and "better."

**Pumpkin Roll Contest***Alice, Golden Empire Council*

Gather at least two large pumpkins – if you don't have the real thing, use a plastic or foam pair. Divide the group of kids into two teams. Line each team behind a pumpkin at the start line. On signal, the first player for each team rolls their pumpkin to the finish line and back again. They tag the next person in line, and in turn every person on both teams does the same thing. First team done wins.

**Needle in a Haystack***Alice, Golden Empire Council*

Gather up a haystack and place within it some prizes, such as candy, small pumpkins and quarters or party favors. Line all of the kids at the starting line and let each player have 30 seconds to find as many things as he can, placing what he finds in a basket. Whichever team or person has the most prizes at the end of the game wins. But everyone gets to keep what they find, so everyone's a winner.

**Corn-Husking Race***Alice, Golden Empire Council*

Boys, dens or families race against each other to see who can husk their pieces of corn first. Or add a challenge: place a pile of corn at a distance from a starting point. On the count of three, the children have to run to the pile, grab a piece of corn, husk it and repeat. The boy, den or family that has husked the most corn in the allotted time wins. If you have a big pot of water boiling, adults can cook up a special treat – complete with butter!

**Disability Awareness Challenges:***Alice, Golden Empire Council*

- **Lower limb mobility:** Tie a dowel or ruler to the back of the leg so that the leg could not bend. Try putting on trousers, shorts, socks, shoes etc. Walk upstairs. Join in a game which involves sitting on the floor and then getting up and running.
- **Upper Limb mobility:** Put "dominant" arm into a sling or tie a dowel to arm so it can't bend or strap fingers together or ....Drink a glass of juice, make a sandwich. Tie a shoe lace
- **Sight problems:** Blindfold boys, or have them wear somebody else's glasses (for a short while only - to avoid eye strain) Put together a jigsaw puzzle. Try drawing a picture. Write your name.
- **Hearing problems:** Wear a walkman or personal radio playing "buzz" (radio tuned between stations) or loud

music. Have them join in a game which relies on hearing.

- **Lots of other ideas in Ethics in Action activities in the How to Book.**

### The Synonyms and Antonyms Game

*Alice, Golden Empire Council*

This game celebrates Noah Webster's dictionary and thesaurus, but it can also lead to a discussion about responsibility, dependability, and loyalty, especially "true" loyalty with peers. (Am I being responsible, or "tattling" when I report something?)

#### Materials:

- ✓ As many dictionaries or thesauruses as you can find;
- ✓ Chalkboard and Chalk or Whiteboard and markers; or even large sheets of paper for each team, with markers;
- ✓ "Scribe" for each team, to write down their answers (Version #2 uses cards instead);
- ✓ Penny candy or some other "reward" for each word found or for the winning team each round.

#### Directions:

Divide boys into two teams. *If you have boys with limited reading skills or learning disabilities, try version #2 of the game and make sure there's a "helper" for each team.*

Write the word SMALL at the top of the board. Leave space to keep score as well. Draw a line down the center of the board and mark one side "Synonym", the other "Antonym". Explain that a synonym is a word that means the same, or almost the same.

Talk about what an antonym is – something that means the opposite. Write an example of each kind of word. Example: Synonym – Petite; Antonym - Large.

Ask the boys if they know where they could find a synonym. *In a thesaurus, but also in a dictionary)* Do they know how to find an antonym? *(Thesaurus, or just using their own ideas)* You might also need to explain how the dictionary or thesaurus is laid out – that they can look at the top of the page to see the range of words on that page. Let everyone look at the word "Small" to see how the books work.

- Now change the word SMALL to RESPONSIBLE on the board. Challenge each team to find one synonym and one antonym. First team that finds one gets a point.
- Extra Challenge: Use the word in a sentence *(See if they notice that the dictionary actually does this)*

Challenge each team to find more words. Give a point to the team that finds the most words in 2 minutes.

- Do the same with the word DEPENDABLE
- Do the same with the word LOYALTY

Then discuss how responsibility, dependability and loyalty help people and how their opposites hurt people. Ask the boys what or who they could be loyal to (country, church, school, employer, friends, family, etc.). Then ask them who should be able to depend on them (parents, teachers, friends, employers, etc.).

What about being loyal to your friends? What if they ask you to lie for them? What if they are doing something

illegal or dangerous? If you are a loyal friend, what would you do? Are you protecting your friend if you "don't tell?" What do they think a truly LOYAL friend would do if they saw you doing something dangerous that could get you in serious trouble? (A truly loyal friend would try to get their friend to see they were doing something wrong and get them to admit it. If they won't you should tell a trusted adult. If you ignore it, your friend could get hurt or in serious trouble – is that what a loyal friend does?)

**Version #2:** Make two sets of cards up ahead of time with the synonyms and antonyms written on them. You can color code the three words, or just put a colored dot on the back, so you can easily sort out the words that go with each main word – Responsibility, Dependability, Loyalty. Then set your game up as a relay – Scatter each team's set of synonym and antonym cards for the first word all around on the floor or on a board at the finish line for each team.

On signal, the first boy in each line races to the finish, and chooses a word – then he must put the word in the right column on the board and race back to tag the next player. When each player on the team has done it, the whole team can race to the finish and double-check to make sure the words are in the right column. They can also make any changes they think need to be done. Then the whole team says, "Done" and sits down.

The adult(s) checks each solution to see which den has the most correct words. The team gets a point for each word in the correct column. Extra points for making a good sentence using the word.

## Food Games

### Minute to Win It "Breakfast Scramble"

*Wendy, Chief Seattle Council*

Challenge boys to assemble puzzles cut from cereal boxes in 1 minute. For more challenge, mix 2 or more puzzles together. Boys can work individually, or cooperate together.

### Cooking Race:

Boys carry vegetables (potatoes, onion, carrots, etc.) on pancake spatula to big pot.

### Popcorn Relay

*Wendy, Chief Seattle Council*

*Fancy footwork is the ticket to success in this event. And everyone's got a unique shuffle, waddle or twist, making this relay, adapted from THE BIG BOOK OF KIDS' GAMES (check with your local library), as much fun to watch as it is to run.*

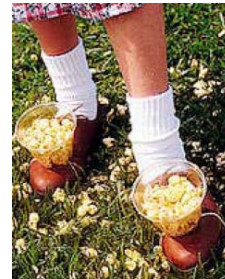

- Beforehand, prepare a pair of plastic or paper cups for each runner. Use a tack or a small nail to poke a hole in the center of each cup bottom. Push one end of a thick rubber band through the hole and into the cup.

- Then, slip a paper clip on the end of the band inside the cup, and gently pull the other end until the clip rests on the bottom of the cup.
- The rubber band, worn around the ball of the foot, holds the cup in place atop a player's shoe.
- Just prior to the race, a member from each team is issued a big bag of popcorn and charged with filling teammates' cups from the moment the starting whistle blows until the relay ends. These individuals stand alongside their teams, behind the starting line.
- Two large, shallow boxes are set 5 yards beyond the starting line, opposite the teams.
- When the whistle blows, the first person in each team's line sprints to the appropriate box and empties his cups into it, trying to lose as little popcorn as possible along the way.
- He then runs back to tag the next person in line. The new runner heads to the team box, and the first runner goes to the end of the line.
- The relay continues for 2 minutes or until one of the bags is emptied. Then, the popcorn in each box is measured with a ruler (or by cupfuls) and the team with the most is declared the winner.

### Pancake Relay

*Wendy, Chief Seattle Council*

#### Required:

- One rope.
- Spatula (*I use homemade ones that are flat versus bent, easier for relay*)
- Flat disc to serve as pancake (*Plastic lid is all right but may be too light. Mark the two sides (1 & 2, top & bottom) so you can tell if pancake was flipped*)

#### Preparation:

Tie rope between two trees or chairs at a nice height for your boys

Have a judge available at the rope for each team.

#### Instructions:

- Divide group into teams
- Line them up a few feet from the rope
- Place spatula and "pancake" on far side of rope
- Boy runs to rope, picks up spatula with "pancake."
- Flips [pancake over the rope. Pancake must land with opposite side up. If opposite side is not up, boy keeps trying until it is.
- After successfully flipping "pancake" boy runs back and tags next boy in line.
- Winner is team that finishes first

## Fire Games

### Where's the Fire Alarm?

*San Gabriel, Long Beach Area, Verdugo Hills Councils*

One boy stands with his eyes blindfolded in the center of a circle formed by the other boys.

The center counts aloud to 20. At the same time the other boys pass a small bell around the circle, ringing it as it travels.

When the counter reaches 20, all the boys in the circle put their hands behind their backs.

The boy in the center takes off the blindfold and tries to guess who has the alarm - the bell.

The boy in the center has three guesses; if he guesses correctly, the boy who held the alarm comes into the center. If not, the counter is blindfolded again, counts to 20 and the game continues as before. *No boy should be permitted to remain in the center of the circle for more than 2 or 3 turns.*

**Remember:** *The boy in the center can turn as the bell rings so he should listen carefully.*

### Fireman, Save My Child

*San Gabriel, Long Beach Area, Verdugo Hills Councils*

- ✓ You will need a drinking straw for each player.
- ✓ Cut paper (the children) into squares of various sizes (2" to 4" square).
- ✓ The players are divided into two teams.
- ✓ Scatter paper squares on a table, about 15 to 20 feet away from the start line.
- ✓ Place a container for each team about 10-15 feet from the table (the course is like a triangle).
- ✓ On signal, the first player from each team runs to the table with his straw and picks up a square by sucking up the paper against his straw.
- ✓ While holding the square this way, each player runs to his respective container and deposits his paper in it.
- ✓ If he drops the square on his way, he must stop and pick it up by sucking it up with his straw.
- ✓ Run this relay style or set a time limit and let everyone play at the same time. When done count the square pieces in the containers.

### Fireman Relay

*San Gabriel, Long Beach Area, Verdugo Hills Councils*

- ✓ You will need a set of Dad's old clothes (or big boots, pants, and suspenders), a bucket and a log for each team.
- ✓ Put blue or white crepe paper streamers 2 to 3 feet long in each fire bucket.
- ✓ Players form two teams.
- ✓ First player puts on a "fireman's suit" (old clothes) on top of his own.
- ✓ He picks up a bucket and runs to a spot about twenty feet away where a log represents a "fire."
- ✓ He pours the "water" (streamers) on the fire, refills the bucket (replaces streamers), and runs back to his team.
- ✓ He takes off his "fireman's suit" and gives it to the next player. The team that finishes first is the winner.

### Fire, Police, Ambulance Game-

*Greater St. Louis Area Council*

Three corners of the room are named "Fire Station", "Police Station", and "Ambulance".

The leader calls out a situation in which a boy might find himself and the Cub Scouts have to run to the correct "corner"

The last one home loses a point for his team.

Suggested situations-

1. Smoke is seen coming from under the door of a house. (Fire Station.)

2. Your window cleaner falls from a ladder while cleaning the upstairs bedroom window (Ambulance.)
3. When out fishing you spot some bushes on fire. (Fire Station.)
4. You see some older boys cutting the wire to a telephone in a call box (Police Station)
5. Your friend falls from his bicycle while you are out for a ride, (Ambulance.)
6. You find a transistor radio pavement. (Police Station.)
7. Your bicycle is stolen. . (Police Station.)
8. An older person who has rescued a small, unconscious girl from a river asks you to telephone for help (Ambulance)

## Sports Games

### 25 RELAY GAMES

*Tatanka District, Sam Houston Area Council*

Use these to fill up a den meeting.

1. **Over the Top** - Play with a medicine ball or basketball. Boy in line in straddle position. Ball passed overhead from boy to boy. Last boy receiving ball vaults over the line as they stand in stooped position. Others continue until first boy finishes.
2. **Through the Tunnel** - Boys in same position. Ball is passed between legs and last boy crawls through, pushing ball ahead with head and hands. Others continue.
3. **In and Out** - Ball is passed between legs and overhead. Last boy runs in and out through the line and others continue.
4. **Over and Under** - Same formation except the balls are alternatively passed overhead and between the legs. Last boy vaults over one and crawls between legs of next boy. Others continue.
5. **Kangaroo** - Ball is passed through line between legs. Last boy tucks ball between knees, jumping on side of line to front, and others continue.
6. **Goat** - Same as above, except that last boy butts ball along side of line with head, not being allowed to use hands.
7. **Leap Frog Race** - Players stand in stoop-stand position as first boy straddle vaults over backs, when he gets down to the end of the line and second boy begins to leap frog jump over line, so continuing until all boys have had their turn jumping over backs of others.
8. **Skin the Snake** - All boys in line stoop over, grasping the left hand of player with his right between legs. Last boy lies down. Line continues backing until all are lying. Return to starting position, all standing. (This should be executed as quickly as possible.
9. **Checker Relay** - You will need: 6 wooden checkers playing pieces per den. Scouts race up and down the hall in relay fashion, with a pile of 6 checkers is balanced on the back of one hand. They are not allowed to steady the pile with the other hand. The only time they can touch the checkers with the other hand, is either when they have dropped them and are picking them up, or when they are transferring the checkers to another scout in their team.
10. **Chinese Ladders** - This game only belongs here insofar as the boys are likely already arranged in the right format to play it. They should sit down the length of the hall facing their partners, with their feet touching those of their partners
11. **Clothespin Relay** - Divide into teams. Each team member must run from the starting line to a team bottle placed a distance away, attempt to drop a wooden clothes pin into the bottle (Each boy has only one attempt to get the clothes pin in the bottle) and run back to tag the next team member, who then repeats the action. The rules are to hold the clothespin with a straight arm at shoulder height or with a bent arm at waist height (as long as all do it the same way). When all the teams are done the team with the most clothespins in their bottle wins the game.
12. **Cotton Ball Race** - Each person has to pick up all the cotton balls with a spatula, keeping it balanced while running to a specified goal and back. If the cotton ball is dropped, the player must start over. When he returns with the cotton ball he places it in a carton.
13. **Crawling Race** - Each scout crawls to a turning line 30 feet away, and returns similarly. Crawling must be on hands and knees; a contestant may not rise to the toe to propel himself.
14. **Driving the Pigs to Market** - The first person in line receives a wand (stick, yardstick, or broom handle) and a pig (soda bottle or egg). On signal the player drives the pig to market and back pushing the pig with his wand.
15. **Eskimo Race** - Each contestant advances, holding the feet together and knees stiff, by quick toe springs. The turning line is about 30 feet distant.
16. **Fifty Yard Swim** - Each boy hops on one foot carrying a paper cup of water. First one over the finish line wins. (Could also be done as a relay.)
17. **2 Ball Hockey Game** - You will need: 2 hockey sticks, 2 balls, or sponge pucks, 4 chairs, 6 skittles or liquid dishwashing soap squeeze bottles. Two equal sized numbered teams on each side of the hall. Two chairs each end for a goal, with a hockey stick and puck in each goal's mouth. A line of skittles between each goal mouth. When a number is called, the two scouts with that number race to their goal mouth, pick up the stick and then dribble the puck between the skittles slalom fashion until they reach the end of the line where they can shoot at the opposing team's goal.
18. **Animal Relay** - the players progressing to the goal and back in the manner, as some animal's walk must vary Relays. Some variations may be: 1) Donkey's walk: traveling on all fours to the goal and imitating the donkey's bray, 2) Duck walk: walking on two feet in squat position squawking without stopping, 3) lame dog: walking on two hands and one foot and barking.

19. **Baby Bottle Race** - Each player runs to a chair, picks up a baby bottle with a slightly enlarged nibble, drinks a small amount (1 oz) of liquid, return and tag next teammate to go.
20. **Barefoot Marble** - Divide the scouts into teams (patrol/den). First boy runs to a line 15 ft. away. He grasps and carries one marble with the toes of each foot, returns to tag the next scout.
21. **Bat Round Relay** - Each player runs to the other end of the field of play, puts their head to the bat (held vertically by the leader), runs around the bat ten times in that position, and then must return to his team without failing down.
22. **Balloon Balance** - Equipment: Per team: 1 big balloon; 1 small balloon. Divide the group into teams of six to eight players. Each team is given one large and one small balloon. The first player of each group, on the word 'Go', balances the smaller balloon on top of the larger one and races to the other end of the playing area. If the top balloon falls off, the player must return to the starting line and begin again. When the 'run' (or walk) is complete, the player takes both balloons in his hands and runs back to the starting line, where the second player is waiting to race. The first team finished, and sitting down, wins.
23. **Blow Cup Relay** - A string is held taut with the string running through a paper cup that is located initially at the one end. Each player must plow the cup to the other end then pushes the cup in line on his team.
24. **Bottle Fill Relay** - Fill a large pop or milk bottle that is held on a player's forehead with a nonbendable cup filled with water.
25. **Candle Race** - First person lights a candle, carries it to a specified point, returns to the next person in line, hands him the candle, all without letting the flame go out. If the flame does go out, he must return to the starting line, relight the flame and start over again.

#### Indoor Track Meet or Outdoor

##### *York Adams Area Council*

A good idea would be to run this track meet on a Den basis, with each Den sending forward its representative before the name of the contest is announced. Use any or all of these

- ★ **Bean Toss:** Give each contestant 10 navy beans and have him try to throw them, one at a time, into a quart jar from a chalk line on the floor.
- ★ **Foot Race:** Have each Cub stand with his feet touching each other, heel to toe. The den with the greatest aggregate length wins.
- ★ **30-inch Dash:** Tack a 30 inch piece of string with a marshmallow at the end on the wall. The first Cub who chews the string and reaches the marshmallow wins.
- ★ **Polo Pan:** Number six 1" cubes on each side: 0-1-2-3-4-5; and use a six hole muffin pan. Let each person throw the cubes into the muffin pan from a distance of 6'. Add the top numbers of the cubes that land in the pan to determine a winner.
- ★ **Bounce Ball:** Use five different-sized rubber balls and a cardboard box. Have the players, in turn, bounce the

balls in the box from 10'. Score 2 points for each ball that goes in.

- ★ **Plumb Ball:** Suspend a golf ball on a cord from the ceiling, using screw eyes. From broom handles, make a set of tenpins, 4" long. Have the players swing the ball and knock down the pins. Score 2 points for each pin knocked over and 10 extra points for a strike. Be sure to catch the ball on the rebound.
- ★ **Hoop Stop:** Lay an 18" hoop made from No. 9 wire on the floor. Use three balls (marble, golf, tennis). Score 5 points for each ball placed inside the hoop in any manner from a distance of 6'.
- ★ **Running High Whistle:** The boy who can hold a whistled note the longest with one breath wins the event.
- ★ **Lightweight Race:** Have the runners carry a lighted candle in one hand and a pail of water in the other. If water is slopped over or if the candle goes out, the contestant is out. The first to cross the finish line wins the race.
- ★ **20 Yard Dash:** Line up the dens for a relay race. Have the contestants carry an egg in a teaspoon held with the arm extended. The first in each line runs 20 yards and back to the next one in line.
- ★ **100 Yard Dash:** Tie a lump of sugar or a marshmallow on the end of 100" string. The contestants gather the string and marshmallows into their mouths without using their hands. The first one to eat the marshmallow wins the race.
- ★ **Obstacle Race:** Place nickels in pans of white flour, or of whipping cream, to see who, with his hands behind him, can be the first to dig them out with his teeth.
- ★ **Sharpshooters:** Hold a contest to see who can throw the most pebbles into the mouth of a jug.
- ★ **Endurance Race:** See who can eat four soda crackers and be the first to whistle a tune.
- ★ **Moving Target:** Have the contestants throw beanbags, sticks, stones, anything for that matter, through a rolling hoop. Score 1 point for each hit.
- ★ **Hobble Race:** Conduct a 100' race with contestants who are bound loosely about the ankles.
- ★ **Long Glum:** The player who can keep from smiling longest, while all the others jeer and laugh, wins.
- ★ **Slipper Throw:** Have the contestants lie flat on their backs and throw slippers over their heads with both feet.
- ★ **Second Obstacle Race:** Make a large number of chalk marks on the floor at the end of the race course. Give each runner a damp rag with which to rub out the chalk marks. The first to clean his section on the floor and run back to the starting line, wins.
- ★ **Swimming Relay:** For this relay race, have each hop on one foot, carrying a glass of water.
- ★ **20 Foot Dash:** Have the relay runners roll lemons or hard-boiled eggs with a stick down the course and back and touch off the next player in line.
- ★ **Bawl Game:** See who can make the most noise for a given period of time.
- ★ **Wide Stretch:** Line up the Sixes with arms extended so that the players are touching, fingers to fingers. See which Six has the longest line.

- ★ **Beans Relay:** Have the relay runners carry beans, one at a time, between match sticks, toothpicks or on a knife.
- ★ **Standing Broad Grin:** The width of the grins measured by judges. The widest one wins this event.
- ★ **Discus Throwers:** Each contestant throws a paper pie plate from a chalk line. The plate must be held flat in the hand and not sailed with the thumb and fingers.
- ★ **16 Pound Put:** Have each contestant put an inflated bag for distance as though it were put from the shoulder.
- ★ **Sponge Shot-Put:** Use a small dry sponge for the shot. See who can put the shot the farthest.
- ★ **Hammer Throw:** Use blown-up paper bags attached to a yard of string. Give each Cub one turn to see who can throw the 'hammer' the farthest.
- ★ **Bottle Roll:** See who can roll a pop bottle from 6' and score a bull's-eye in a chalk ring on the floor. Draw several concentric circles to make targets of different value.

### Semicircle Soccer (A Semicooperative Game)

*Bay Area Council*

The idea for this game came from a game called Konta Wai in Papua, New Guinea. In Konta Wai, two semicircles of about five players each stand facing each other about 12 feet (3-1/2 meters) apart. The fruit of a local tree is thrown, lifted like a hockey puck, or batted back and forth between the semicircles with the use of sticks. The main object of the game is to try to prevent the fruit from passing through one's own semicircle of players. Semicircle Soccer takes off from here and adds a few new wrinkles.

#### To play:

- ✓ Two separate semicircles, of four or five players each, are formed by linking arms around the next person's waist.
- ✓ Semicircles begin by facing each other and kicking a sponge soccer ball back and forth.
- ✓ The objective of each team is to prevent the other team from kicking the ball through its semicircle.
- ✓ However, both semicircles are mobile. They can move at will and can kick the ball from anywhere on the play space.
- ✓ They can even attempt to get around behind the other semicircle in order to kick the ball through their unit in a rear attack.
- ✓ Additional Semicircles and balls can be added for more action.

### Fitness Circle Game

*Tatanka District, Sam Houston Area Council*

Form a circle as large as the room permits with all Cub Scouts facing the same direction. Give instructions for various activities as follows:

1. Start walking in a circle, and keep walking between these exercises.
2. Start hopping.
3. Make yourself as small as possible and continue walking.
4. Make yourself as tall as possible and continue walking. Now reach your hands high over your heads.
5. Bend your knees slightly, grasp your ankles, and continue walking.

6. Walk as if the heel of one foot and the toes of the other were sore.
7. Walk stiff-legged.
8. Squat down and jump forward from that position.
9. Walk on hands and one foot with the other leg held high, imitating a dog with a lame foot.
10. Walk forward at a rapid pace (don't run) while swinging your arms vigorously.
11. Take giant steps.
12. Walk forward, raising your knees as high as possible with each step.
13. Run, lifting your knees high.
14. Walk on your hands and feet.

*This is a great set of directions for a Simon Says Game CD*

### Hodge Podge Ball

*Tatanka District, Sam Houston Area Council*

#### Equipment:

4 people minimum, one tennis ball and a variety of items (one per player) that can be used to hit the tennis ball such as plastic bats, pots, pans, large sticks, fly swatters, kitchen utensils, etc.

#### Directions:

- ★ Players are gathered in a large circle.
- ★ One player bats the tennis ball with his utensil to another player in the circle.
- ★ The receiver tries to send the ball to another member of the circle.
- ★ The ball bounces once between each hit.
- ★ If a person fails to receive the tennis ball or send it to another player, he is eliminated.
- ★ The game continues until one player is left, then everyone passes his utensil one person to the right and the game begins again.
- ★ The choice of utensils makes the game a success.

### ABC Sports

*Sam Houston Area Council*

Scouts sit in a circle.

Taking turns, each Scout names something that has to do with sports or sporting events (A is for archery, B is for bobsled, C is for competition, etc.).

### Hop, Skip, and Jump down the Trail

*Sam Houston Area Council*

- ◆ Divide the Scouts into two teams.
- ◆ Let each team practice hopping, skipping, and jumping until they are comfortable with these actions.
- ◆ The first Scout on each team takes a hop, a skip, and then a jump from the starting line.
- ◆ The next Scout also takes a hop, a skip, and then a jump, but he starts from the heel mark of the Scout who went before him.
- ◆ This continues until each member of the team has had a turn.
- ◆ The team who covers the farthest distance wins.



### Crab Soccer

*Sam Houston Area Council*

**Materials** – 1 ball and 4 chairs

*This is a version of football that can be played indoors using chairs as goal posts.*

The rules are much the same as normal football with the exception that Scouts must be in the crab position - that is, on hands and feet/heels with back toward the ground.

You may want to make additional rules to prevent the goalkeeper from throwing the ball too far across the hall. For example, the ball must bounce at least once on his side of the hall.

### Bike Games

*The next seven game ideas are from Utah National Parks Council, and are definitely Fun with A Purpose – each game helps develop bicycle skills!*

#### 1. Use Your Beanie:

Use chalk to draw a racetrack with a lane for each contestant. The course can be straight, wavy, circular or any combination, as long as the lanes are at least 6 feet wide and run parallel to each other. (School yards and church parking lots are ideal for this!) But staying on course is just part of the challenge in this contest. Riders must also balance a beanbag (or substitute a zip-top bag filled with rice in a pinch) on top of their helmets! First person across the finish line without losing his beanbag wins. For a greater challenge, see who can balance the tallest stack of beanbags.

#### 2. Toe The Line:

Use the same course as above – but the twist is that each contestant must keep their front and back wheels on their own chalk lines at all times. Whoever gets the farthest first while staying on their lines wins – even if they don't get to the finish line!

#### 3. Can It:

Set up a bunch of empty soda cans or 2-liter bottles to form a large circle on the ground. One at a time, boys take a turn pedaling around the circle. Anyone who knocks over a "marker" bottle or can is disqualified. Whoever finishes "clean" in the shortest time wins.

#### 4. Tortoise Tango:

This is another variation of the slow race – the key to winning is to make like a tortoise and take it slow and steady. The aim is to finish LAST – a lot harder than it sounds! Use chalk to draw 3 foot wide parallel lanes spaced 10 feet apart on a paved surface. Length can vary, but 50 feet makes a good distance. Mark starting and finishing lines in both lanes. Riders must travel down their assigned path as slowly as possible, keeping their feet on the pedals at all times. Last one to cross the finish line without putting down their feet is the winner.

#### 5. Pursuit Race:

This is a speed race. All riders line up around a circular course about three yards apart. On signal, they all ride in the same direction around the circle. The idea is for a rider to pass the rider in front of him. As a rider is

passed, he is eliminated. The race continues until there is only one left. **Warning: Use this only if the boys are all about the same size and skill level, and if the race can be done without injury or argument!**

#### 6. Obedience Test:

All players except one form a large circle at least 30 feet across, 6 feet from each other. The remaining player mounts his bike inside the circle and slowly rides toward one of the other boys. When he is about halfway across, the player he is riding towards calls out a command, such as "Turn right" or "Stop" The rider must give the proper signal and carry out the command. He continues to ride, carrying out commands given him by other boys, until he has had five commands. Then he switches places with a boy in the circle. When everyone has had a chance to ride, total scores – the one with the fewest penalty points wins. Scores: one point against each time a rider who fails to signal, gives the wrong signal, or does the wrong action.

#### 7. Potato Race:

Teams line up with their bikes in relay style. A box is placed on the starting line in front of each team. At 5 yard intervals or more in front of each team, mark four circles into which a potato or beanbag is placed before the game begins. On signal, the first player in each team rides out and picks up the potato in the first circle, returns to the starting line and puts it in the box. He then rides out for the second, third and fourth in the same way. When he has put each of the potatoes in the box, he passes off to the second player, who must return the potatoes, one at a time, to the circles. Continue until every member of the team has had a turn.

### Tire Games

*Santa Clara County Council*

**Tire Sprint:** Racers line up with forward edge of tire at the starting line. On signal, they push tire forward and continue to push it across finish line. If necessary, establish lanes.

**Roll for Distance:** Each player rolls his tire separately and is entitled to run to gain speed and momentum but must stop at the stopping line while the tire rolls forward by itself.

**Roll for Accuracy;** Same as above, except tire is rolled at a target of 2 sticks set 3-4 feet apart and approximately 20 feet away.

**Moving Target:** Players take two turns rolling tire parallel to other players 15 – 20 feet away who try to throw balls or beanbags or broomsticks through the tire as it rolls by.

**Tire Wrestling:** Place two tires on the ground so they touch each other. One contestant stands in each tire. As the signal, they wrestle to throw or push their opponent out of his tire. The winner is the first to cause the other to fall or step out of his tire, provided he himself remains on his feet in his tire.

**Tire Bowling:** Bowl, using discarded tires in place of balls, with milk cartons or tin cans for bowling pins. Arrange "alley" on the ground with the bowling line 20 – 30 feet from the pins. Each bowler rolls two tires. Score as in bowling.

**Tire Rolling Relay:** Form teams and give the first player of each team a tire. Place a stake or chair opposite each team on the turning line. At the signal, the first player rolls his tire to the turning line, rolls it around the stake and back to the next player in line.

**Through the Tire Relay:** Establish a rolling line in front of the lines of dens. The first player of each team goes up to the rolling line with a tire. At signal he rolls his tire forward toward his team by giving it one shove. The players in turn then straddle-jump the tire. If the roller did not steer the tire exactly straight, the line must shift in order to be in line with their tire. If a player knocks the tire down in attempting to jump it, or if it falls over before he can jump it, he must recover the tire and give it to the player in front of him who rolls it for him and the rest of the team. The original roller then takes place at the front of the line. When the last man has jumped the tire, he rolls it to the starting line, and the action is repeated until the original roller has rolled the tire back to the starting line.

## Law Enforcement Games

### Follow the Clues

*Timucua District, North Florida Council*

This activity will take a little time to put together and has to be based on where you will meet when you run the activity. List out a bunch of things that are in the meeting place and a clue as to what each is. Depending on the boys' level, you can make the clues appropriately hard/easy.

For example:

- Den Flag – Blue cloth with Number 4 on it that says what our Cub Scout group is.
- American Flag – A flag that stands for the nation.
- Advancement Poster – Where we track how well you are doing learning new things and completing activities.
- Craft Table – Where we gather to make special items with glue and paper.
- Supplies Box – Where the Den Leader stores materials for the Den Meetings
- Stairs – The up & down machine you used to get to the basement.
- Good Conduct Candle – What should stay shining bright throughout the meeting.
- Main Door – The entry way to the meeting.

Write out the clues on separate index cards (or inside folded sheets of paper) and attach each clue to an object to which the clue doesn't refer. (In other words, don't put the den flag clue on the den flag).

As each boy arrives, give him a sheet of paper with a starting point for him to follow the clues.

Explain that at his starting point he will find a clue to another object in the room and that he's to go to that object, write down what it is, and then follow the new clue at that object to get to the next one until he has followed all of the clues that lead back to his starting point.

After the opening ceremony, have the boys take turns reading off the objects to which the clues led them until all of the objects have been identified.

### Who am I?

*Wendy Chief Seattle Council*

- ☺ The boys form a circle
- ☺ One person is chosen to be guesser, and goes into the middle of the circle of players. The guesser is blindfolded.
- ☺ A leader spins the guesser, and the circle spins in the opposite direction.
- ☺ When the spinning stops, the guesser points in the direction of the circle, and says the name of an animal.
- ☺ The person he points to makes the noise that animal makes.
- ☺ The guesser tries to guess who made the animal noise.
- ☺ If he is correct, the person becomes the guesser and the guesser takes his spot in the circle. Otherwise, the guesser has to go again.

### Assassin:

*Wendy Chief Seattle Council*

- ★ Players sit in a circle, with legs crossed.
- ★ Children put heads down, and close their eyes.
- ★ A leader walks the circle, and taps one child on the head to choose the assassin.
- ★ Everyone opens their eyes.
- ★ The assassin eliminates the other players by winking at them.
- ★ If you are winked at, silently count to 10, then put your feet into the middle of the circle.
- ★ If the assassin eliminates everyone, he wins.
- ★ The assassin can be "witnessed."
- ★ If a player thinks he knows who the assassin is before he gets winked at, he can say he has a suspect. For example, "I suspect that Tommy is the assassin."
- ★ If Tommy is not the assassin, then the accuser is eliminated.

### Bomb Squad:

*Wendy Chief Seattle Council*

- ✓ Leaders hide 3 alarm clocks in 3 different places.
- ✓ The clocks are set to ring at intervals of 5, 6, and 7 minutes.
- ✓ Players must find the clocks before they all ring, and the "bombs" go off.
- ✓ A less scary version is to just challenge the boys to find the alarm clocks before they go off.

## CUB GRUB

*Note: Prepare simple, fun meals to emphasize responsibility. Milk shakes, ice cream, or soup are good possibilities for cooperative effort. Catalina Council*

### Cool PBC Shake

*Catalina Council*

#### Ingredients:

- 1/2 cup whipping cream
- 1/2 cup milk
- 1 teaspoon vanilla
- 3/4 cup sugar
- 2 ounces baking chocolate
- 1/2 cup peanut butter
- 2 cups ice

**Instructions:**

1. Put all ingredients in order into a blender.
2. Blend until smooth.
3. Enjoy!

**Kick the Can Ice Cream***Catalina Council***Ingredients:**

- 1 pint of half and half
- 1/3 cup granulated sugar
- 4 tablespoons of your favorite instant pudding mix (chocolate was used here)
- 10 cups ice
- 1 ½ cup rock salt (kosher salt or sea salt can be used too)
- 3-pound coffee can, emptied and rinsed
- 1-pound coffee can, emptied and rinsed
- Duct tape

**Instructions:**

1. In a medium bowl, combine half and half, sugar, and pudding mix with a whisk until thoroughly mixed.
2. Place 1-pound coffee can inside the 3-pound coffee can and pour ice cream mixture into smaller can. Cover the smaller can with its corresponding lid and seal with duct tape.
3. Surround the smaller can with ice and salt by layering 5 cups of ice with 3/4 cup of salt.
4. Use duct tape to seal the 3-pound can with its corresponding lid and start rolling. Have the kids face each other and roll the can back and forth on its side for 10 minutes.
5. After 10 minutes, open the cans and check the ice cream. Remove the smaller can and check the ice cream. The mixture on the sides of the smaller can will set up faster than the center. Use a rubber spatula to quickly scrape down the sides and give the ice cream one stir.
6. Next, reseal the lid on the smaller can with duct tape, and set it aside. Quickly dump the melted ice water from the large can, and place the smaller can into the larger can again.
7. Now you need to surround the smaller can with remaining ice and salt by repeating step 3. Once that is done, put the lid on the larger can and seal with duct tape again.
8. Ask the kids to roll the large can for 10 minutes more.
9. Once they're done, open the cans again and serve the ice cream to your little helpers!

**Tips:**

- ✓ Use your favorite flavor of pudding to change the ice cream flavor.
- ✓ After the first 10 minutes of kicking around the can, mix in some nuts or chocolate chips to enhance the flavor of your ice cream.
- ✓ If the boys get tired of kicking that can around after only 10 minutes, take this shortcut: Stir the mixture and set it in the freezer for about an hour to allow the rest of it to harden.

**Acorn Doughnuts***Alice, Golden Empire Council***Ingredients:**

- Chocolate Frosting or Peanut Butter
- Donut Holes
- Crumbled Toffee or Nuts
- Pretzel

**Directions:**

- ✓ Frost the top third of a plain doughnut hole with the frosting or peanut butter.
- ✓ Roll the frosted top in crumbled toffee or nuts.
- ✓ Add a small piece of pretzel at the top for a stem.
- ✓ **Enjoy with milk ~ this would be the perfect snack after helping with the Acorn Project** – See information under Den & Pack Activities or check under Web Sites.

**Pizza Mummies***Alice, Golden Empire Council***Ingredients**

- English muffins
- Pizza sauce
- Black olives
- Scallions
- Red or green pepper
- Cheese sticks or slices

**Directions:**

- ✓ Heat the oven to 350° F. For each mummy,
- ✓ Spread a tablespoon of pizza sauce onto half of an English muffin (toast it first, if you like).
- ✓ Set olive slices in place for eyes and add round slices of green onion or bits of red or green pepper for pupils.
- ✓ Lay strips of cheese or pulled-apart cheese stick across the muffin for the mummy wrappings.
- ✓ Bake for about 10 minutes or until the cheese is melted and the muffin is toasty.

**"Food" Food****Hot Dog Octopus***Russ, Timucua District**This is always a favorite at Day Camp CD***Ingredients**

- Weiner
- A sharp knife

Note: If the Cubs haven't earned their whittling chip yet, have an adult perform the cutting operation(s). Caution those Cubs who use knives to handle them properly.

**Directions:**

1. Cut the bottom 3/4 of a wiener into 8ths, using vertical cuts. Leave the top 1/4 intact.
2. Boil the wiener as you normally would.
3. When done, the Cubs now have a crazy octopus with wavy arms!

**Pancake Faces***Great Salt Lake Council***Ingredients:**

Pancake batter  
 Food color  
 Favorite pancake toppings

**Directions:**

- ✓ Heat griddle.
- ✓ Mix up your favorite pancake batter.
- ✓ In a small bowl pour a cup of the pancake batter and mix in a food color.
- ✓ Spray the griddle with nonstick cooking spray.
- ✓ Using a spoon, with the colored batter, make eyes, nose and mouth on the griddle (pancake size).
- ✓ Pour the regular pancake batter on top covering the face.
- ✓ When the edges are crisp and the bubbles are popping on top, turn the pancake.
- ✓ **Voile!** You have a face! Try making aliens, monsters or your favorite animal.
- ✓ Serve with your favorite pancake toppings.

**Grilled Cheese Dippers***Great Salt Lake Council***Ingredients:**

White or wheat bread  
 Softened butter or margarine  
 American cheese singles  
 Swiss cheese singles  
 Mild salsa

**Directions:**

- ✓ Heat griddle.
- ✓ Spread butter or margarine on the outside of the bread.
- ✓ Place a slice of American cheese on the inside of one slice of bread and the Swiss cheese on the top of the American cheese;
- ✓ Place the unbuttered side of the other slice of bread on the top of the cheeses.
- ✓ Place the sandwich on the hot griddle and cook until golden brown, turn and cook the other side as well.
- ✓ Move to a cutting board and let cool for 5 minutes.
- ✓ Dish the salsa into a small dish.
- ✓ Cut the sandwich into 4 rectangle strips.
- ✓ To eat, dip the sandwich strips into the salsa.

**Super Kiss***Russ, Timucua District***Ingredients**

(makes two to four kisses)

Butter or margarine, 1 stick  
 Miniature marshmallow, 1 package, 16 ounces  
 Plain or chocolate crisp rice cereal, 12 cups

**Equipment:**

Large plastic kitchen funnels, two or more  
 Ribbon of choice  
 Large saucepan,  
 large spoon  
 Cookie sheet,  
 plastic wrap  
 Scissors  
 measuring cup

**Directions:**

1. Coat inside of plastic funnels with butter or margarine and cover cookie sheet with plastic wrap; set both aside.
2. Melt butter or margarine in saucepan over a low to medium heat; add marshmallows.
3. Heat until marshmallows are completely melted, stirring constantly.
4. Remove from heat and add cereal;
5. Stir until cereal is well coated.
6. Cool slightly, but not completely.
7. Lightly butter fingers; press mixture into plastic funnel.  
*Note: Using more than one funnel at a time will speed up shaping process.*
8. Place filled funnel on plastic-covered cookie sheet.
9. Let cool.
10. Unmold kiss and cover with plastic wrap closed.

**Bugs On A Log***Russ, Timucua District***Ingredients**

Celery  
 Peanut butter or cottage cheese  
 Raisins, sunflower or sesame seeds

**Directions:**

Stuff celery with the peanut butter or cottage cheese. Sprinkle with raisins or seeds and enjoy.

**Chocolate Spiders***Russ, Timucua District***Ingredients**

1 12 oz. bag semi-sweet chocolate chips  
 1 6 oz. bag butterscotch chips  
 1 7 oz. can salted peanuts  
 1 3 oz. can chow mein noodles

**Directions:**

In a medium saucepan over very low heat, melt the chocolate and butterscotch chips. Quickly stir in the peanuts and chow mein noodles. Drop by spoonfuls on wax paper and refrigerate until hard.

**"Fire" Food****Hot "Hero" Sandwich***San Gabriel, Long Beach Area, Verdugo Hills Councils***Ingredients:**

- 4 crispy fried bacon slices
- ½ cup mayonnaise or salad dressing
- 1 cup shredded Cheddar cheese
- ½ cup dry roasted peanuts
- ½ teaspoon celery salt
- 1 teaspoon Worcestershire sauce
- 2 green onions, chopped
- 4 English muffins or 8 slices of bread, toasted

**Directions**

- ✓ Mix mayonnaise, Worcestershire sauce and celery salt in a bowl.
- ✓ Stir in cheese, onions and peanuts. (Watch for allergies)
- ✓ Crumble bacon into mixture. Stir.
- ✓ Fill each sandwich with ½ cup of the cheese mixture.
- ✓ Place one sandwich on a paper napkin and microwave on high 20 to 25 seconds.
- ✓ Makes 4 servings.

**Fire Hose***(Santa Clara County Council)***Ingredients:**

- 1½ cups apple juice
- 2 envelopes unflavored gelatin
- 3 oz. package any flavor Jell-O
- Ice cubes

**Directions**

- ✓ Heat half the apple juice to boiling.
- ✓ Add the Jell-O and stir to dissolve.
- ✓ Soften unflavored gelatin in remaining apple juice and add to hot Jell-O.
- ✓ Stir to dissolve.
- ✓ Add ice cubes and stir until melted.
- ✓ Refrigerate 15 minutes.
- ✓ Spoon into a Zip-Loc bag.
- ✓ Cover cookie sheet with plastic wrap.
- ✓ Cut corner off plastic bag and squeeze out small amount of Jell-O in shape of a hose.
- ✓ Chill 2 hours.
- ✓ Eat!!

**Firehouse Chili Dog Casserole***San Gabriel, Long Beach Area, Verdugo Hills Councils***"It's like eating a chili dog, but with a fork."****Ingredients:**

- 8 hot dog buns
- 8 hot dogs
- 1 (15 ounce) can chili
- ¼ cup chopped onion
- 1 tablespoon prepared mustard
- 2 cups shredded Cheddar cheese

**Directions**

- ✓ Preheat oven to 350°F (175°C).
- ✓ Lightly grease a 9x13" baking dish.
- ✓ Tear up the hot dog buns and arrange the pieces in the bottom of the dish evenly.

- ✓ Slice the hot dogs into bite size pieces and layer the pieces over the buns.
- ✓ Pour the chili over the hot dogs,
- ✓ Sprinkle with the chopped onion,
- ✓ Then spread some mustard over the chili and the onion.
- ✓ Top off with the cheese.
- ✓ Bake at 350°F (175°C) for 30 minutes.
- ✓ Original recipe yield: 6 to 8 servings

**Firefighter Chili Cheese Dip***San Gabriel, Long Beach Area, Verdugo Hills Councils***Ingredients:**

- 1 (8 ounce) package cream cheese, softened
- 1 (15 ounce) can chili
- 1 cup shredded Cheddar cheese

**Directions**

- ✓ In the bottom of a 9" microwave safe round baking dish, spread the cream cheese.
- ✓ Top the cream cheese with an even layer of chili.
- ✓ Sprinkle Cheddar cheese over the chili.
- ✓ Heat in the microwave on high heat 5 minutes, or until the cheese has melted.
- ✓ Serve with your favorite chips or vegetables.

**Chili**

Get a package of any of the various Alarm Chilis (e.g. 3 Alarm) and mix and serve according to directions

**Sports Food****Skateboard Sandwiches***Sam Houston Area Council***Ingredients –**

- Your Favorite sandwich
- Milk
- Carrot sticks
- Black olives
- Food coloring
- Water
- Ice cube tray

**Directions –**

1. Remove the crust from the edges of the sandwich and trim the edges so that they are rounded like a skateboard.
2. Mix 3 Tbsp of milk with food coloring and place separate colors in the individual ice cube tray sections.
3. Using a new, clean water color brush, dip the brush into the colored milk and decorate the skateboard. Use the water to rinse the brush between colors.
4. To add wheels and axles, place an olive on the ends of two carrot sticks and lay the sandwich on top of both carrots.

**Mini Football Subs***Great Salt Lake Council***Ingredients**

- Meat balls
- Spaghetti sauce
- Shredded cheese
- Individual-size rolls

**Directions**

- ★ Combine meatballs and spaghetti sauce in a skillet and warm them through.
- ★ For each sub, cut a V-shaped notch from the top of an individual-size roll,
- ★ Place meatball in the roll, and top with cheese shred laces.
- ★ Finally, get the sandwiches in a huddle on a cookie sheet and
- ★ Place them in a warm oven for a few minutes to melt the cheese.

**Football Pudding***Great Salt Lake Council***Ingredients**

- 1 package instant pudding mix
- Milk called for in directions on package
- 2 re-sealable bags

**Directions**

- ☞ Pour both milk and pudding mix into a plastic bag.
- ☞ Squeeze all the air out and seal.
- ☞ Place first bag in second bag and squeeze all the air out, seal.
- ☞ Stand in a circle and toss the “football” around for about five minutes.
- ☞ When pudding is done snip the corner of the bags and squeeze into cups for serving.

**Peanuts***York Adams Area Council*

Just get a bag of fresh roasted peanuts in their shells.

**First Aid Food****Band aid Treat:**

- ☺ Break a large rectangular graham cracker into 4 small rectangles.
- ☺ Put a small marshmallow in the center of each of the small rectangles.
- ☺ Microwave 10-15 seconds.

**Bike Food****Cookie Wheels***Alice, CS RT Commissioner**Pioneer District, Golden Empire Council***Ingredients:**

- 1-1/2 cups all purpose flour,
- 1/2 cup of softened butter or margarine,
- 1/4 cup of powdered sugar,
- 1/2 teaspoon baking powder,
- 1 Tablespoon of milk,
- 1 cup of pie filling or jam (your choice of flavor)

**Directions:**

- ✓ Preheat the oven to 375 degrees.
- ✓ Mix the flour, margarine, sugar, baking powder and milk just enough milk to form a dough. *If more milk is needed, add it by teaspoonfuls only.*
- ✓ Divide the dough into 6 equal parts,
- ✓ Then shape into balls.
- ✓ Place on an ungreased cookie sheet; flatten slightly.
- ✓ Make an indentation 1-3/4 inches across and about 3/4 inch deep, in the center of each flattened ball.

- ✓ Now fill each indentation with about 2 Tablespoons of filling.
- ✓ Bake until edges begin to brown (20-25 minutes).  
Makes 6 “Wheels”

**Ice Cream “Lollipops”***Trapper Trails*

For each lollipop, use a scoop to shape ice cream into a ball. Roll in shredded chocolate, chopped nuts, toasted coconut, or crushed candy or cookies.  
Insert Popsicle stick.  
Store in covered container in freezer.

**Homemade Bike Energy Bar***Trapper Trails***Ingredients**

- 1/4 cup butter, melted or oil
- 8 large egg whites, beaten
- 3/4 cup whole-wheat flour
- 1/4 cup wheat germ
- 1/2 teaspoon baking powder
- 1/2 cup nonfat dry milk powder
- 3/4 cup rolled oats
- 1 teaspoon salt
- 3/4 cup brown sugar
- 2 cups chopped dried fruit
- 2 1/2 cups nuts, chopped
- 3/4 cup chocolate chips (optional)
- 1/4 cup sesame seeds

**Directions**

- ✓ Preheat oven to 350 degrees.
- ✓ Grease a 9x13 pan.
- ✓ Beat together eggs and oil.
- ✓ Sift together dry ingredients except fruit.
- ✓ Add flour to eggs, combine,
- ✓ Then stir in fruit, nuts, and chips.
- ✓ Spread evenly in pan,
- ✓ Bake 30 minutes; they are still soft when done.
- ✓ Cool, cut into 24 pieces, wrap in foil and freeze.

**Frozen Wheels***Trapper Trails***Ingredients**

- Chocolate chip cookies
- Chocolate or vanilla ice cream, softened
- Colored sprinkles or mini chocolate chips

**Directions**

Create a wheel by sandwiching ice cream between two cookies.  
Roll the edges of the “wheel” in colored sprinkles or mini chocolate chips.  
Freeze until ready to eat.

## Law Enforcement Food

### Thumbprint Cookies

Wendy Chief Seattle Council  
*These were a big hit at RT!!*

#### Ingredients:

- 1 c. butter
- 2 c. flour
- 1 tsp. vanilla
- 1/2 c. powdered sugar
- 3/4 c. quick oats
- Strawberry or grape jam
- 1 tsp. vanilla

#### Directions

- ✓ Beat butter, sugar, vanilla until fluffy.
- ✓ Add flour, oats, mix well.
- ✓ Chill dough.
- ✓ Remove from refrigerator, form into 1 inch balls and place on baking sheet.
- ✓ Press thumb into center of each ball and fill with jam.
- ✓ Bake at 350 for 15 minutes.

## WEBELOS

Joe Trovato,  
 WEBELOS RT Break Out Coordinator  
 Westchester-Putnam Council

Have a question or comment for Joe??

Write him at

[webelos\\_willie@yahoo.com](mailto:webelos_willie@yahoo.com)

There is an underscore between Webelos and Willie



## WEBELOS

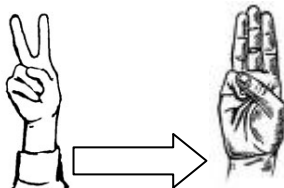

## WEBELOS-to-Scout Transition

One of the most important, but perhaps least discussed responsibility of both a first year and second year Webelos adult leader is to include activities in the program to prepare WEBELOS for the eventual transition to Boy scouts. Those of you that have followed my contributions to this section of

Baloo know that I often include references to preparation for Boy Scouts in and about Webelos activities.

Our aim should be to make the transition an easy one for the boys. Webelos leaders and parents share in this responsibility.

- Start early
- Visit Troop meetings
- Organize joint den/troop campouts
- Visit troop activities
- Discuss options with adults and boys
- Encourage completion of the Arrow of Light
- Promote the move to Boy Scouts to both Webelos and parents.

Leaders of a fifth grade Webelos den should plan out transition activities during the six months that the boys are earning their Arrow of Light. In fact, besides the activity badges, requirements to earn the Arrow of Light include preparation to join a Boy Scout troop, troop visit, outdoor activity, an overnight campout or day hike and a scoutmaster conference.

The following is a sample checklist for activities to support transition to Boy Scouts:

### September

- ❑ Have your den select a Scout patrol name, get patrol patches to wear, make a patrol flag, and elect a Patrol Leader. Check the Scout Handbook for ideas.
- ❑ Provide parents with an outline for their role in the transition. (*I provide a sample below JT*)

### October

- ❑ Ask you Roundtable Commissioner to sponsor an information sheet exchange to allow den leaders to provide contact information to Boy Scout leaders. The sheets may be given out at the October Roundtable and returned to the November Roundtable. This is very important so that Troops can send you information regarding open house opportunities and invite your den to Troop meetings, Courts of Honor, and outdoor activities. (*Note: make sure that activities are age appropriate*  
<http://www.scouting.org/filestore/pdf/ageguides.pdf> and  
<http://www.scouting.org/filestore/pdf/510-631.pdf> for Webelos JT)

- ❑ Leaders should begin visiting local Troops in your area personally and meet their Scoutmasters. A key factor in a successful Webelos-to Scout transition is a working partnership between the pack and the Boy Scout troop.

### November

- ❑ Take your Webelos and their parents to visit Troop meetings for at least 2 different Troops.
- ❑ Encourage your Webelos to make a final decision on joining a Troop. Make sure that they understand that they need to make their choice by January. Scoutmasters can be attendance at Blue & Gold in February.

**December**

- ❑ Assist the Cubmaster in planning a top-notch, personalized graduation for the Blue & Gold Banquet in February.

**January**

- ❑ Assist your Webelos in the completion of their Arrow of Light requirements.

**February**

- ❑ Graduate your Webelos into Boy Scouts. Have them complete a Scout application and register with a Troop. New Scouts should have a Scout Handbook by this time (*a great present from the Pack to graduating WEBELOS. JT*).

**March**

- ❑ Be sure that new Scouts have a schedule and begin attending Troop meetings in their new Troop(s). Encourage parents to get involved as Patrol advisors or in the Troop Committee.
- ❑ Talk to the Scoutmaster of your Troop and volunteer to work with the new Scouts as a New Scout Patrol advisor (or better yet an Assistant Scoutmaster). This will help boys become comfortable in the new Troop.
- ❑ Follow up with any of your Webelos as to why they did not join a Troop.

As mentioned, parents have an important role in a successful WEBELOS-to-Scout transition. As soon as your meetings begin in September, provide the parents with a document which sets out their roles. The following sample is used by some dens to guide their parents and should be adapted to meet your particular situation:

**September**

- ❑ Meet with your Webelos Leader regularly to discuss the Webelos-to-Scout transition process. Make sure you understand when things will happen so that you can help prepare your Webelos. Volunteer to assist in any way.
- ❑ Refer to the Webelos-to-Scout transition often and tell your Webelos how proud you are that he will soon become a Boy Scout. Use positive terms that convey an expectation that your son will continue in Scouting.
- ❑ Assist your son in the completion of his Arrow of Light requirements.

**October**

- ❑ Provide your Webelos leader with the birth date of your son as well as your latest contact information. Your Webelos leader will need this information to help local Troops prepare for Webelos recruiting.
- ❑ Talk with your Webelos leader about the Troop visits that happen in November or December.
- ❑ Find out about the local Boy Scout Troops in our area using a Troop Directory available from your Webelos leader or by visiting an online directory provided by your local council. Make sure that the Troops you want to visit are included by the WEBELOS leader or visit them separately.

**November**

- ❑ Encourage your son to make a final decision on joining a Troop. Make sure that they understand that they need to have their choice completed by January so that

Scoutmasters can be attendance at Blue & Gold in February.

**December**

- ❑ Consider providing your son with a Boy Scout Handbook during the holiday season. Encourage him to read the handbook and find out what Boy Scouts do.

**February**

- ❑ Graduate your son into Boy Scouts. Have them complete a Scout application and register with a Troop. New Scouts should have a Scout Handbook by this time.

**March**

- ❑ Make sure that your new Scout has a Troop schedule and is attending Troop meetings. Volunteer your time as a Patrol advisor, Assistant Scoutmaster or in the Troop Committee.
- ❑ Pay attention to your son's involvement and his level of enthusiasm for Scouting. Most boys fit into a particular Troop seamlessly but others do not. If you believe that your son would do better in a different Troop, use the Troop directory to begin your own Troop visits to other Troops. Once your registration dues are paid you can transfer to another Troop for \$1 just by completing another Boy Scout application. It's that easy.

**Meeting Planner**

This month's meeting plans for first year Webelos to be introduced to Webelos Badge requirements and provide activities to finish up on Forester and Naturalist and work on Traveler and Athlete. Second year Webelos plans call for work on Outdoorsman and Sportsman.

**Flag Ceremony**

As discussed last month, you should ensure that a formal flag ceremony be performed at your den meeting and at the monthly Pack meeting. I like adding something that is "month appropriate" to the basic ceremony. October means Columbus Day. Following the posting of the flag and before the color guard is dismissed, one of the Webelos may add something like the following (from about.com):

"The second Monday in October is designated in the United States as Columbus Day. This day commemorates Christopher Columbus' first voyage and sighting of the Americas on October 12, 1492. The first recorded ceremony commemorating Columbus in America occurred in 1792, 300 years after his famous first voyage in 1492. To honor Columbus, a ceremony was held in New York, and a monument was dedicated to him in Baltimore, Maryland. In 1892, a statue of Columbus was raised at Columbus Avenue in New York City. Further, at the Columbian Exposition held in Chicago that year, replicas of Columbus' three ships were displayed.



Italian-Americans were key in the creation of Columbus Day. Beginning on October 12, 1866, New York City's Italian population organized a celebration of the 'discovery' of America. This yearly celebration spread to other cities and became known as Columbus Day in San Francisco in 1869.

Colorado became the first state to observe an official Columbus Day in 1905. Over time other states followed until 1937 when President Franklin Roosevelt proclaimed every October 12 as Columbus Day. In 1971, the federal holiday was officially changed by Congress to be observed on the second Monday in October. However, Columbus Day as a federal holiday was not officially recognized until 1937.”

**Den Activities**



These activities can be used for the gathering or to reinforce/satisfy badge requirements.

**Forester/Naturalist**



**FOREST FUN**

Fill in the blanks with the name of the tree it reminds you of.

Sumac Walnut Mesquite Rubber Oak Spruce

Ash Elder Pine Orange Apple Locust

1. \_\_\_\_\_ A person who is old
2. \_\_\_\_\_ Something that stretches
3. \_\_\_\_\_ A bright color
4. \_\_\_\_\_ A nut
5. \_\_\_\_\_ Small insect
6. \_\_\_\_\_ Another name for cleaning up
7. \_\_\_\_\_ OK with an A in the middle
8. \_\_\_\_\_ A present for a teacher
9. \_\_\_\_\_ The most "knotty" wood
10. \_\_\_\_\_ The sound a slap makes
11. \_\_\_\_\_ Fire leftovers
12. \_\_\_\_\_ A city in west Texas

**Answers:**

1. Elder A person who is old
2. Rubber Something that stretches
3. Orange A bright color
4. Walnut A nut

5. Locust Small insect
6. Spruce Another name for cleaning up
7. Oak OK spelled with an A in the middle
8. Apple A present for a teacher
9. Pine The most "knotty" wood
10. Sumac The sound a slap makes
11. Ash Fire leftovers
12. Mesquite A city in west Texas

**FOREST TREES AND THEIR USEFUL WOOD PRODUCTS**

Write the letter of the wood product on the right, next to the correct tree variety on the left.

- |                                    |                               |
|------------------------------------|-------------------------------|
| ___ Cedar                          | A. pulpwood for paper, lumber |
| ___ Redwood                        | B. lumber, turpentine, tar    |
| ___ Long Leaf Pine                 | C. lumber, telephone poles    |
| ___ Pecan, Oak, Ash                | D. shingles                   |
| ___ White Pine                     | E. furniture                  |
| ___ Douglas Fir or, Ponderosa Pine | F. weather-resistant lumber   |

**Answers:**

- D Cedar
- F Redwood
- B Long Leaf Pine
- E Pecan, Oak, Ash
- A White Pine
- C Douglas Fir, Ponderosa Pine

**Naturalist - SPECIES OF NATURE**









Fill in all the empty category squares with words beginning with the letter for that row. If you cannot think of a name for that category, leave it blank and go on. Then, compare answers with the others







	Animal	Bird	Fish	Flower	Tree
N					
A					
T					
U					
R					
A					
L					
I					
S					
T					



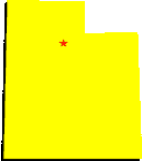

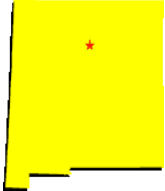

Traveler/Athlete

Traveler - BEEN THERE FUN

(Copy and paste into a separate sheet to spread out the descriptions and States - JT)

	I am famous for producing lots of maple syrup
	Mount Rushmore is one of my more popular tourist sites.
	Dorothy and Toto are a couple famous "residents."
	I'm home to the Grand Canyon.
	The Rio Grande separates my southern border from Mexico
	I am home to the Liberty Bell
	I am home to Pikes Peak, one of the highest peaks in the Rockies
	My nickname is the Golden State

	I have one very large salty lake
	Three of my major lakes are Lake Tahoe, Lake Mead and Lake Mohave.
	I am home to the Carlsbad Caverns National Park
	The widest river in the USA shares my name
	I'm home to the Ozarks, Gateway Arch, and Silver Dollar City
	I am surrounded by four Great Lakes
	My nickname is the Sunshine State

	Most of Yellowstone National Park is in my north region.
	I am the largest state in land size
	My name is from the Choctaw words "okla" & "homme"
	I am spread over many islands
	I am home to over 10,000 lakes
	The Chesapeake Bay divides much of my land area
	I'm famous for a horse derby and rolling green hills.

**Traveler - COLOR OF SIGNS**



Different colors on signs have a meaning. Match each color from the list to the appropriate meaning below.

Red      Orange      Yellow      Green      Blue

- \_\_\_\_\_ is used to identify distances and directions.
- \_\_\_\_\_ means coming to a hazardous area or area with special rules.
- \_\_\_\_\_ is used for road construction area.
- \_\_\_\_\_ means stop or use caution.
- \_\_\_\_\_ is used to show information.

**Outdoorsman -**

**BUILDING A FIRE**



Before you cook outdoors you must have a fire. Remember that the fire makes the success of the cooking. Learn when to have a quick hot fire, when to have good coals, when to plan for a fire that burns for a long while. Firebuilding and cooking go hand in hand.

Building a fire is a big responsibility. Build a fire only where and if you have permission. You need a grown up around when building a fire. Care of the fire and fire prevention becomes the responsibilities of the person who lights the match. A good camper knows not only how to light a fire, but also how to put it out. When he is finished, he makes sure every ember is out and cleans up the fire site.

**Wood Fires**

Have and safe and suitable place for your fire. It could be built in a park, a campsite or a driveway. Clear away anything that can burn - leaves, grass, paper, etc.

Have a bucket of water ready to put out the fire.

Collect your equipment before you start.

For a fire to burn three things are required:

- FUEL - material that will burn.
- HEAT - enough heat to bring fuel to ignition.
- AIR - to provide oxygen for burning process.

When one of the three things is removed, the fire stops burning. Water cools fuel below ignition point, dirt cuts off the oxygen supply.

A fire needs three different kinds of fire material - tinder, kindling and fuel. The match lights the tender, the tender lights the kindling, and the kindling starts the fuel burning.

- TINDER - should start to burn as soon as it is touched with a lighted match. Use thin twigs, tops of dried weeds, wood shavings, dryer lint, etc.
- KINDLING - is little sticks and can be as small as a pencil or as thick as your thumb.
- FUEL - is the larger wood that keeps your fire going. Do not use green or freshly cut wood, it does not burn well.

Stack the wood in three separate piles far enough away from the fire, so that no sparks can fly into stacks.

### Building Your Fire

Using larger pieces of wood, form an "A" on the ground. Get your tinder and kindling. You will need two handfuls of kindling. Put the tinder on the "A" instead of the ground. This way the tinder has air underneath it and there is space for your match.

Light the match. Kneel near the fire and strike the match away from you. Tip the match down so that the flame catches on the match stick. On a windy day, kneel with your back to the wind and cup your hands around the match.

Now light the tinder. Carefully add more tinder. You may need to blow at the base of the fire.

Add kindling. When the tinder has started to burn, add kindling. Start with small pieces. Remember to keep close together but allow space for air.

### Types of Fire

- **TEPEE FIRE:** This a good fire for quick cooking since the heat is concentrated on one spot. It looks like a tepee. Stack the fuel over the foundation fire. The foundation fire will start the fuel burning. Add fuel as you need it.
- **CRISSCROSS FIRE:** This type is long lasting and makes good coals. It is good for a campfire. To make this, lay fuel over the foundation fire in a crisscross pattern. Be sure to leave room for air. Add fuel as needed.
- **REFLECTOR BAKING:** This type of fire is built against a high back of rocks or logs; a wire screening over coals is good for roasting corn.

After you are finished with your fire make sure it is out by:

- Scattering ashes or embers
- Sprinkling with water
- Drenching charred logs
- Covering with dirt or sand

When you can hold your hand on the spot where the fire was and not feel any warmth, your fire is out.

### Outdoorsman -FOIL COOKERY

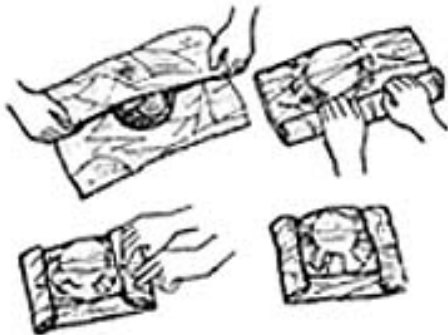

### Foil Cooking Hints

Use two layers of light-weight, or one layer of heavy duty aluminum foil. Foil should be large enough to go around food and allow for crimping the edges in a tight seal. This

will keep the juices and steam in. This wrap is know as the "drugstore" wrap.

### Drugstore Wrap

Use heavy foil three times the width of the food. Fold over and roll up the leading edges. Then roll sides for a steam proof seal.

A shallow bed of glowing coals that will last the length of cooking time is necessary.

### Cooking Times:

- ★ Hamburger: 8-12 minutes,
- ★ Carrots: 15-20 minutes
- ★ Chicken pieces: 20-30 minutes,
- ★ Whole Apples: 20-30 minutes
- ★ Hotdogs: 5-10 minutes,
- ★ Sliced potatoes 10-15 minutes

### Foil Dinner

- ★ Lay slices of potatoes, onion, and carrots on a sheet of heavy-duty foil then place hamburger patty on top.
- ★ Cover with slices of potato, onion, and carrots.
- ★ Season with butter, salt and pepper.
- ★ Cook 20-30 minutes over hot coals, turning twice during cooking.

### Cardboard Box Oven



A cardboard box will make an oven. Cut off the flaps so that the box has four straight sides and bottom. The bottom of the box will be the top of the oven.

Cover the box inside and out **COMPLETELY** with foil, placing shiny side out.

To use the oven, place the pan with food to be baked on a footed grill over the lit charcoal briquets. The grill should be raised about ten inches above the charcoal. Set the cardboard oven over the food and charcoal. Prop up one end of the oven with a pebble to provide the air charcoal needs to burn - or cut air vents along the lower edge of the oven. Control the baking temperature of the oven by the number of charcoal briquets used. Each briquette supplies 40 degrees of heat (a 360 degree temperature will take 9 briquets).

Experiment! Build an oven to fit your pans - or your menu: Bake bread, brownies, roast chicken, pizza or a coffee cake. Construct a removable oven top or oven door. Punch holes on opposite sides of the oven and run coat hanger wire through to make a grill to hold baking pans. Try the oven over the coals of a campfire

**Sportsman -**

**THE PENALTY BOX**



FOOTBALL BASKETBALL BASEBALL SOCCER HOCKEY

Match the Officials' signal calls to the correct sport

- Pass Interference \_\_\_\_\_
- Holding the Face Mask \_\_\_\_\_
- Slashing \_\_\_\_\_
- Fair Ball \_\_\_\_\_
- Ball \_\_\_\_\_
- Incomplete Pass \_\_\_\_\_
- Penalty Kick \_\_\_\_\_
- Holding \_\_\_\_\_
- Safe \_\_\_\_\_
- Tripping \_\_\_\_\_
- Illegal Dribble \_\_\_\_\_
- Kneeing \_\_\_\_\_
- Time-out \_\_\_\_\_
- Offside \_\_\_\_\_
- Hooking \_\_\_\_\_
- Strike \_\_\_\_\_
- Out \_\_\_\_\_
- Clipping \_\_\_\_\_
- Unsportsmanlike Conduct \_\_\_\_\_
- Illegal Motion \_\_\_\_\_
- Technical Foul \_\_\_\_\_
- Time-in \_\_\_\_\_
- Charging \_\_\_\_\_
- Substitution \_\_\_\_\_
- Corner Kick \_\_\_\_\_
- Touchdown \_\_\_\_\_
- Delay of Game \_\_\_\_\_
- Foul Ball \_\_\_\_\_
- Traveling \_\_\_\_\_
- Foul \_\_\_\_\_

**Sportsman – MORE ACTIVITIES**

- Visit a sports shop and talk with the owner about selecting equipment.
- Play some backyard games such as horseshoes. Croquet, Volleyball or badminton
- Have a parent/son game.
- Visit a racquet club or tennis court.
- Have a sports hero Den meeting. Have each boy prepare a presentation on his hero and why he is a person to look up to. Stress sportsmanship and the reasons this sports hero is a good person, not just a player.

**More Webelos Stuff**

*Here are some more ideas for Webelos from Wendy at Chief Seattle Council  
Thank you from CD*



Webelos Badge requirements,  
Naturalist,  
Forester,  
Traveler,  
Athlete,  
Geography Belt Loop

**Den Meeting #3: Hiking Field trip.**

**Webelos Badge:**

- #3 Meaning of Webelos badge;
- #4 Webelos uniform;
- #6 Flag ceremony;
- #7 Boys Scout requirements.

**Naturalist:**

- #6 Bird flyways;
- #7 Poisonous plants and venomous reptiles;
- #9 ecosystem producers, consumers, & decomposers.

**Forester:**

- #5 Tree picture;
- #6 Tree rings.

**Den Meeting #4**

Verify Athlete 4-7

**Traveler:**

- #9 Map legend;
- #10 2 routes on map to interesting place;
- #1 Transportation time table;
- #11 Traveling safety precautions.

**Geography Belt Loop (Traveler #12):**

- #1 Draw neighborhood map;
- #2 Learn about the physical geography of your community;
- #3 World globe geography.

**Naturalist:**



For more ideas see

[2008 July RT/Aug Theme Baloo's Bugle](#)

[2009 July RT/Aug Theme Baloo's Bugle](#)

Or almost any July RT/Aug Theme issue of Baloo's Bugle.

**Bird Games**

Sparrow Sparring, [How To Book](#) , p. 3-31.  
 Stork Wrestling, [How To Book](#) , p. 3-32.  
 Crows & Cranes, [How To Book](#) , p. 3-7.  
 Duck, Duck, Goose,  
[http://en.wikipedia.org/wiki/Duck,\\_duck,\\_goose](http://en.wikipedia.org/wiki/Duck,_duck,_goose)

**Feather Games:****Keep it Up:**

Individuals or group blows on feather, keeping it up in the air as long as possible. For more challenge, use 2 or more feathers. <http://www.nbc.com/minute-to-win-it/how-to/keep-it-up/>

**Race I, Regular Relay Race:**

Players blow feather toward finish line. 2 versions:

- #1: Players blow or fan feathers on the ground.
- #2: Players must keep feathers in the air.

**Race II: Obstacle Relay Race**

Players blow feathers through an obstacle course.  
 2 versions:

- #1: Players blow or fan feathers on the ground around obstacles.
- #2: Players must keep feathers in the air while they go around or under obstacles.

**Insect Activities:** [How To Book](#) , p. 4 - 17 to 20.

**Decomposer Tie Slide:**

*Liz, Chief Seattle Council*

Hot glue plastic bug to artificial leaf.  
 Hot glue small stretchy ponytail holder or piece of PVC pipe to back of leaf for ring. – Liz, Chief Seattle Council

**Don't Bug Me Door Hanger:**

<http://www.makingfriends.com/dontbug.htm>

Could use paper bugs instead of woodsie bugs.  
 Realistic/gross bugs may appeal more to Webelos than cute bugs.

**Bird Activities:**

Look at feathers under high powered magnifying glass (available at REI).

**Forester Ideas**

For more ideas see

[2008 July RT/Aug Theme Baloo's Bugle](#)

[2009 July RT/Aug Theme Baloo's Bugle](#)

Or almost any July RT/Aug Theme issue of Baloo's Bugle.

**Tree Activities:** [How To Book](#) , p. 4 - 9 to 12.

**Traveler Ideas**

For more ideas see:

[2009 May RT/June Theme Baloo's Bugle](#)

[2010 May RT/June Theme Baloo's Bugle](#)

Or almost any May RT/June theme issue of Baloo's Bugle.

**Traveler Games & Gathering Activities:**

Car & Driver, [How To Book](#) , p. 3-15;  
 Traveler Game, [How To Book](#) , p. 3-38.

**Arrow of Light**

Outdoorsman,  
 Sportsman,  
 Ultimate Belt Loop

**Den Meeting #3****Outdoorsman:**

- #1 Camping preparation;
- #2 Plan an outdoor activity that includes a campfire;
- #5 Leave no Trace;
- #7 Outdoor fire safety;
- #8 Help prep, cook, & cleanup a meal during a camp out;
- #10 Whip & fuse rope ends;
- #11 Use 2 half hitches and taut line hitch to set up tent or dining fly.

**Den Meeting #4****Sportsman:**

- #1 Signals used by sports officials;
- #2 Good sportsmanship;
- #4, Partial earn 2 team sport belt loops (Ultimate Belt Loop)

**Outdoorsman:**

[2009 April RT/May Theme Baloo's Bugle](#)

[2010 Apr RT/May Theme Baloo's Bugle](#)

Or almost any April RT/May theme issue of Baloo's Bugle.

**Campfire Ideas:**

Check out the materials published for these themes -

- ☞ 2005 Campfire Tales & Traditions:  
<http://www.scoutingthenet.com/Training/Roundtable/Handouts/05/07/>
- ☞ 2009 "A Camping We Will Go"  
<http://www.scoutingthenet.com/Training/Roundtable/Handouts/09/05/>
- ☞ 2003 "A Hiking We Will Go":  
<http://www.scoutingthenet.com/Training/Roundtable/Handouts/03/06/>
- ☞ 2009 "Leave Nothing But Footprints":  
<http://www.scoutingthenet.com/scouting/Training/Roundtable/Handouts/09/04/>
- ☞ Skit resource for campfire programs:  
<http://www.macscouter.com/Skits/index.asp> Be sure to check any skits selected against current Grey Area guidelines!!

**For Fire Safety - Try the Edible Campfire:****Edible Campfire I**

Use this for a patrol activity to teach proper fire building techniques. As boys are building their individual fires, explain why each step is important. After the fire is built, enjoy eating this treat!



**Materials -**

- Napkin or Coffee Filter – designates a cleared area
- Miniature marshmallows for fire circle
- Small cup of water – to extinguish fire
- Shredded coconut – kindling
- Skinny pretzels – tinder
- Fat pretzels – fuel
- or Tootsie Rolls*
- Candy corn – fire
- or Red Licorice*

**FIRE SAFETY**

Mark True statements with T and False statements with F

- \_\_\_\_\_ Build fires close to your tent.
- \_\_\_\_\_ Be sure fire is downwind from tents.
- \_\_\_\_\_ Keep cooking fires as large as can be. They'll cook faster.
- \_\_\_\_\_ Clear an area ten feet in diameter of all burnable material, or as required by local laws.
- \_\_\_\_\_ Place ten fire buckets filled with water at each tent.
- \_\_\_\_\_ Always extinguish fires and other flame sources before you go to sleep.
- \_\_\_\_\_ Put fires dead out with any liquid you have on hand.
- \_\_\_\_\_ Never leave a fire unattended.

**Edible Fire II and III**

Teach the art of fire building by letting the participants make an edible fire. Make sure you OK the fire before they consume it! Use frosting to assemble one of the following lists into an edible fire:

**Plan II**

- Napkin = base
- Small Marshmallows = fire ring
- Flaked Coconut = kindling
- Red Hots or Raisins = coals
- Candy Corn = fire
- Pretzel Sticks = logs
- Kool-Aid = water to put out fire

**Plan III -**

- Large cookie = base
- Peanut M&Ms = rock ring
- Potato Sticks = kindling
- Pretzel Sticks = logs
- Candy Corn = fire
- Tootsie Rolls = fuel wood
- Granola = dirt Small cup
- Small cups = water buckets

**Campfire Tie Slide:**



See picture and instructions at <http://cubclub.tripod.com/craft4.html>

**S'more Tie slide:**

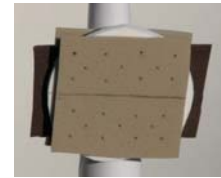

**Materials:**

- Thick white foam
- 2 pieces 1 3/4" x 1 3/4" light brown foam
- 1 1/4" x 2 1/2" dark brown foam
- PVC ring
- Pen
- Scissors
- Hot glue
- Pencil

S'mores are made by first roasting a marshmallow. Stick a marshmallow on the end of a long stick or wire and rotate it over hot coals until it turns light brown. Place part of a chocolate bar on a graham cracker, place the marshmallow on top of the chocolate and cover it with a second graham cracker. Then pull out the stick or wire. Be very careful because the wire will get very hot. The wire or stick can easily poke someone else because your attention is focused on the S'more you just made and are getting ready to eat. For the marshmallow, you can use thick craft foam or shape a piece of Styrofoam with a knife and sandpaper.

**Directions:**

1. Cut out the pieces.
2. Use a glob of hot glue in the middle of a "graham cracker" to attach the dark brown chocolate.
3. Use another glob of hot glue in the middle of the "chocolate" to attach the "marshmallow".
4. Place another glob of hot glue on top of the "marshmallow" to attach the second "graham cracker".
5. Using a pencil, draw the line and small dots on the light brown craft foam to resemble the indentation marks of a graham cracker as shown in the photo above.
6. Attach a PVC ring to the back with a drop of hot glue.

*I cut up a cork sheet for the graham crackers, and used a cotton ball for the marshmallow. Wendy*

**Homemade Hiking or Outdoor Gear**

Make hiking or outdoor gear from duct tape -



<http://jas.familyfun.go.com/arts-and-crafts?page=CraftDisplay&craftid=11203>

Hiking sticks:

<http://jas.familyfun.go.com/arts-and-crafts?page=CraftDisplay&craftid=10078>

<http://familyfun.go.com/arts-and-crafts/season/feature/famf97project/famf97project23.html>

Use real sticks, or cut up PVC pipe and decorate.

Trail Tote:

<http://jas.familyfun.go.com/arts-and-crafts?page=CraftDisplay&craftid=11741>

Emergency Rain Poncho:

Make poncho from garbage bag. Make hat from plastic grocery bag. Fold, and put in zip lock baggie. Decorate baggie with stickers.

[http://www.makingfriends.com/scouts/poncho\\_camping.htm](http://www.makingfriends.com/scouts/poncho_camping.htm)

### Outdoor Cooking:

<http://usscouts.org/usscouts/bbugle/bb0905.pdf>  
p.20,23-4.

[How To Book](#) , p. 4 - 32-39.

[http://www.macscouter.com/CubScouts/PowWow07/SCCC\\_2007/CubScoutThemes/Aug\\_2007.pdf](http://www.macscouter.com/CubScouts/PowWow07/SCCC_2007/CubScoutThemes/Aug_2007.pdf) p.10-16.

*Great cooking ideas here!! Wendy.*

### Hiking:

Check out the information for the "Leave Nothing but Footprints" theme for good hiking information:

<http://www.scoutingthenet.com/scouting/Training/Roundtable/Handouts/09/04/>

*Magnifying glasses and binoculars can make walks/hikes more interesting for the boys. Wendy*

### Sportsman



<http://usscouts.org/usscouts/bbugle/bb0903.pdf> p. 33-35.

For more sportsman ideas, look at the March issues of Baloo.

[2009 March RT/April Theme Baloo's Bugle](#)

[2010 March RT/April Theme Baloo's Bugle](#)

Or almost any March RT/April theme issue of Baloo's Bugle.

### Sportsman Games & Gathering Activities:

<http://usscouts.org/usscouts/bbugle/bb0906.pdf>

2009 Baloo's Bugle "Be a Sport" p. 10-11, 34-39.

### For more sportsman ideas, look at:

2008 Olympic theme "Go for the Gold":

<http://www.scoutingthenet.com/Training/Roundtable/Handouts/08/05/>

2002 "Sports Extravaganza" theme:

<http://www.scoutingthenet.com/Training/Roundtable/Handouts/02/07/>

2009 "Be a Sport" theme:

<http://www.scoutingthenet.com/Training/Roundtable/Handouts/09/06/>

2010 "Hoop-de-Doo" theme:

<http://www.scoutingthenet.com/Training/Roundtable/Handouts/10/05/>

2005 "Play Ball" theme:

<http://www.scoutingthenet.com/Training/Roundtable/Handouts/05/06/>

### Frisbee Games

**(to help boys practice skills for Ultimate):**

#### Lickety-Split Frisbee

*Besides a disc, all it takes to get a volley match under way is a twist of the wrist.*

#### What You Need

- One Frisbee for each team

#### Instructions

1. Kids pair up and stand a certain number of feet apart (determined by the team's skill level).
2. The object is to sail the disc back and forth as many times as possible in one minute.
3. Each successful pass scores one point.
4. Catching the disc under a leg, behind the head, or on the tip of a finger earns two points.

#### Double Disk Frisbee

*This Frisbee game, filled with fancy throws and catches, is perfect for quick fun on a lazy summer day.*

#### What You Need

- Two or more Frisbees
- Chalk or rope

#### Instructions

1. Mark a 20-foot line on the ground with chalk or a piece of rope and position two players or teams facing each other on opposite sides of the line.
2. Pass the discs back and forth simultaneously. The object is to avoid having both discs on one side of the line at the same time.

#### Ultimate Disc Frisbee

*Like football, this scaled-down version of the official game requires two teams and two goal lines.*

#### What You Need

- Frisbee

#### Instructions

1. Begin with each group standing behind its goal line. One team throws the disc into the other's end zone. The receiving team must try to move the disc up field using a series of passes.
2. Each time a player catches the disc, she must stop in her tracks and throw it to a teammate before taking another step. The player may pivot on one foot. To keep the game moving, put a time limit (10-15 seconds) on how long a player may hold the Frisbee before passing.
3. The defending team (not passing) is awarded the disc following a score, an incomplete pass, an out-of-bounds pass, or an interception.
4. To score a point, the receiving team must complete a pass to a player positioned behind the opponents' goal line. The first team to score 21 points wins the game (or whatever point goal you set).



## POW WOW EXTRAVAGANZAS

### Cape Cod and Islands Council

#### **Pow Wow - 21<sup>st</sup> Century**

October 16, 2010

Christ the King Parish Hall, Mashpee, MA  
Call Cape Cod & Islands Council, (508) 362-4322, or visit the website <https://www.scoutscapecod.org/training/pow-wow.html> ,for more information

### Chief Seattle Council

#### **Program and Training conference**

October 16, 2010

North Seattle Community College, Seattle, WA  
Call Chief Seattle Council, (206) 725-5200, or visit the WEBSITE <http://www.seattlebsa.org/Training/2010-Program-Training-Conference>,for more information

### Sam Houston Area Council

#### **Following Akela's Trail into the Next Century**

November 6, 2010

Location - TBA

Call Sam Houston Area Council, (713) 659-8111, or visit the website, [http://www.samhoustonbsa.org/akelas\\_trail.php](http://www.samhoustonbsa.org/akelas_trail.php) ,for more information

### Southern NJ Council

#### **Improving Your 'Scoutability'**

January 22, **2011**

Lakeview Middle School, Millville, NJ 08332  
Call Southern NJ Council, 856-327-1700, extension 32, or visit the website, [www.njscouting.org](http://www.njscouting.org) for more information

## WEB SITES



*Alice, Golden Empire Council*

[www.firesafetv.gov/citizens/escape/index.shtm](http://www.firesafetv.gov/citizens/escape/index.shtm) - You can download a grid to create an outline of your home and show all the exits; specific ideas on how to deal with babies, toddlers, older people, rural fire safety; also a Kids section, with games, coloring pages and hints – available in Spanish also

[www.familyfun.go.com/recipes/teaching-kids-to-cook-714658](http://www.familyfun.go.com/recipes/teaching-kids-to-cook-714658) Great ideas on teaching kids to be responsible when cooking.

[www.firesafetv.gov/](http://www.firesafetv.gov/) downloadable graphics, coloring pages, games and activities for kids; also specific information about all kinds of fires and how to prepare

[www.psychcentral.com/lib/2006/building-responsible-kids/](http://www.psychcentral.com/lib/2006/building-responsible-kids/) Great, practical techniques to use to help kids be responsible

## ONE LAST THING

### WHO DID IT?

There is a story about four people. Their names are EVERYBODY, SOMEBODY, ANYBODY, and NOBODY. The story goes that there was a very important job that needed to be done. EVERYBODY was asked to do this job. Now ANYBODY could have done this job but NOBODY was willing to do it. Then SOMEBODY got angry about this because it was EVERYBODY'S job to do. Well, EVERYBODY thought that ANYBODY could have done it! But NOBODY realized that. EVERYBODY blamed SOMEBODY for not doing the job. Still NOBODY did it. The arguing got worse and finally NOBODY would talk to ANYBODY and EVERYBODY blamed SOMEBODY. What a shame that ANYBODY could have done the job and EVERYBODY could have helped SOMEBODY but yet NOBODY did it!

If there is something you know must be done, don't wait for ANYBODY else to do it or hope that SOMEBODY else will do it because NOBODY else will do it unless you show EVERYBODY else how to do it.

### *Translating to Scouting terms -*

#### **Somebody, Everybody, Anybody, Nobody**

Once there were four Scouters. Their names were: Tom Somebody, Dick Everybody, Harry Anybody, and Joe Nobody. They were very active and busy people; but what they accomplished was a shame and Everybody knew it. For example, Everybody had a good idea. Everybody thought Somebody would follow it through. Somebody thought Anybody would work on it. Anybody thought Everybody should do it. So Nobody ended up working on it. Now they all belonged in the same district and a great contest was on. Who could produce the best pack? Everybody thought Anybody would win the prize. Anybody thought Somebody would win it. Somebody thought Everybody would win it. Nobody was the most qualified of the four. Nobody was very faithful. Nobody worked very hard. Nobody won the contest. Which of the four received the prize? Nobody - - But Nobody!

#### **RIP - Someone Else**

The pack was saddened this week to learn of the death of one of our most valuable members, Someone Else. Someone's passing creates a vacancy that will be difficult to fill. He had been with us for years and for every one of those years, Someone did far more than a normal person's share of the work. Whenever leadership was mentioned, we looked to this wonderful person for inspiration as well as results: "Someone else can do that job." When there was a job to do, a need to be filled, or a place of leadership, one name always mentioned was Someone Else. It is common knowledge that Someone Else was among the largest givers of time and money in the pack. Whenever there was a financial need, everyone assumed that Someone Else would make up the difference. Now Someone Else is gone. We wonder what we are going to do. No longer can we say, "Let Someone Else do it." If it is going to be done, one of us will have to do it.